

1300

 MIRADOR

134 GALLON / 507 LITRE / 507 LITRO / 507 LITER

**STORAGE BOX
BOÎTE DE RANGEMENT
AUFBEWAHRUNGSBOX
OPBERGBOX**

**INSTRUCTION MANUAL / MANUEL D'INSTRUCTIONS /
BEDIENUNGSANLEITUNG / GEBRUIKSAANWIJZING**

LIFE SERIES / SÉRIE LIFE / LIFE-SERIE / LIFE SERIE



EN THANK YOU FOR PURCHASING OUR DECK BOX!

This manual will provide you with clear and detailed instructions on how to safely and correctly assemble and maintain your deck box to ensure it brings you many years of use and enjoyment.

IMPORTANT, RETAIN FOR FUTURE REFERENCE: READ CAREFULLY

Warning: Important safety instructions. It is important for the safety of persons to follow these instructions. Please keep these instructions in a safe place.

Any use or modification to the deck box not included in this manual shall be considered as improper use, which may cause considerable danger to users and property and will void the product warranty.

Please only use this product for its intended purpose within a residential environment. Failure to do so will void your warranty. This item is intended for outdoor domestic use only. Not for commercial use.

We reserve the right to make changes for product improvements.

For parts and customer service, please email customerservice@miradoroutdoor.com

Digital instruction manual is also available on our official website www.miradoroutdoor.com for your reference.

FR MERCI D'AVOIR ACHETÉ LA BOÎTE DE RANGEMENT MIRADOR !

Ce manuel vous fournira des instructions claires et détaillées sur la manière d'assembler et d'entretenir correctement et en toute sécurité votre boîte de rangement, afin qu'elle vous apporte de nombreuses années d'utilisation et de plaisir.

IMPORTANT, À CONSERVER POUR DE FUTURS BESOINS DE RÉFÉRENCE : À LIRE SOIGNEUSEMENT

Avertissement : Instructions de sécurité importantes. Il est important pour la sécurité des personnes de suivre ces instructions. Veuillez conserver ces instructions dans un endroit sûr.

Toute utilisation ou modification de la boîte de rangement non incluse dans ce manuel sera considérée comme une utilisation incorrecte, ce qui pourrait entraîner un danger considérable pour les utilisateurs et les biens, et annuler la garantie du produit.

Veuillez utiliser ce produit uniquement à des fins prévues dans un environnement résidentiel. Le non-respect de cette consigne annulera la garantie du produit. Cet article est destiné à un usage domestique extérieur uniquement. Non conçu pour une utilisation commerciale.

Nous nous réservons le droit d'apporter des modifications pour améliorer le produit.

Pour obtenir des pièces détachées et un service clientèle, veuillez envoyer un e-mail à customerservice@miradoroutdoor.com.

Le manuel d'instruction numérique est également disponible sur notre site officiel, www.miradoroutdoor.com pour votre référence.

DE

VIELEN DANK FÜR DEN KAUF UNSERER MIRADOR AUFBEWAHRUNGSBOX!

Dieses Handbuch enthält klare und detaillierte Anweisungen, wie Sie Ihre Aufbewahrungsbox sicher und korrekt montieren und warten können, damit Sie viele Jahre lang Freude an ihr haben.

WICHTIG: FÜR SPÄTERE NUTZUNG AUFBEWAHREN: SORGFÄLTIG LESEN

Warnung: Wichtige Sicherheitshinweise. Für die Sicherheit von Personen ist es wichtig, diese Anweisungen zu befolgen. Bitte bewahren Sie diese Anweisungen an einem sicheren Ort auf.

Jegliche Verwendung oder Änderung der Aufbewahrungsbox, die nicht in diesem Handbuch enthalten ist, gilt als unsachgemäße Nutzung. Dies kann erhebliche Gefahren für Benutzer und Eigentum verursachen und führt zum Erlöschen der Produktgarantie.

Bitte verwenden Sie dieses Produkt nur für den vorgesehenen Zweck in einer privaten Umgebung. Andernfalls erlischt Ihre Garantie. Dieses Produkt ist nur für den häuslichen Außenbereich bestimmt und nicht für den kommerziellen Gebrauch geeignet.

Wir behalten uns das Recht vor, Änderungen zur Produktverbesserung vorzunehmen.

Für Ersatzteile und Kundenservice senden Sie bitte eine E-Mail an customerservice@miradoroutdoor.com.

Eine digitale Bedienungsanleitung finden Sie auch auf unserer offiziellen Website www.miradoroutdoor.com.

NL

BEDANKT VOOR UW AANKOOP VAN ONZE MIRADOR OPBERGBOX!

Deze handleiding biedt u duidelijke en gedetailleerde instructies over hoe u uw opbergbox veilig en correct kunt monteren en onderhouden, zodat u er jarenlang plezier van heeft.

BELANGRIJK: BEWAAR VOOR TOEKOMSTIGE REFERENTIE: LEES ZORGVULDIG

Waarschuwing: Belangrijke veiligheidsinstructies. Het is belangrijk voor de veiligheid van personen dat deze instructies worden opgevolgd. Bewaar deze instructies op een veilige plaats.

Elk gebruik of elke wijziging van de opbergbox die niet in deze handleiding is opgenomen, wordt beschouwd als onjuist gebruik. Dit kan aanzienlijke gevaren voor gebruikers en eigendommen veroorzaken en de productgarantie ongeldig maken.

Gebruik dit product alleen voor het beoogde doel in een residentiële omgeving. Het niet naleven hiervan maakt uw garantie ongeldig. Dit artikel is alleen bedoeld voor gebruik buitenshuis in een particuliere omgeving. Niet voor commercieel gebruik.

Wij behouden ons het recht voor om wijzigingen aan te brengen voor productverbeteringen.

Voor onderdelen en klantenservice kunt u een e-mail sturen naar customerservice@miradoroutdoor.com.

De digitale handleiding is ook beschikbaar op onze officiële website www.miradoroutdoor.com voor uw referentie.

EN LIST OF PARTS

FR LISTE DES PIÈCES

DE TEILELISTE

NL ONDERDELENLIJST

04 Before Assembling Your Deck box
Avant d'assembler votre boîte de rangement
Vor dem Zusammenbau Ihre Aufbewahrungsbox
Voordat u uw opbergbox monteert

07 Important Safety Advice
Conseils de sécurité importants
Wichtige Sicherheitshinweise
Belangrijk veiligheidsadvies

10 List of Parts
Liste des pièces
Liste der Teile
Onderdelenlijst

24 Assembly
Assemblage
Montage
Montage

50 Care & Maintenance
Entretien et maintenance
Pflege und Wartung
Verzorging en onderhoud

51 Warranty & Complaints Procedure
Garantie et procédure de réclamation
Garantie- und Reklamationsverfahren
Garantie- en klachtenprocedure

EN BEFORE ASSEMBLING YOUR DECK BOX

FR AVANT D'ASSEMBLER VOTRE BOÎTE DE RANGEMENT

DE VOR DEM ZUSAMMENBAU IHRER AUFBEWAHRUNGSBOX

NL VOORDAT U UW OPBERGBOX MONTEERT

EN **WARNING: Important safety instructions. Follow all instructions, since incorrect assembly can lead to severe injury.**

Check to ensure there are no missing parts:

Before you begin assembly, please check that you have all the parts required to assemble your product. Please also carefully check that the quantity of parts matches with that of the model you have purchased.

If any parts are missing, please refer to the **Warranty & Complaints Procedure** to contact customer service before beginning the assembly.

Prepare the parts you will need for each step:

In the **Assembly** section of the manual, each step indicates the necessary parts and quantities required to complete the step. We recommend that you prepare the parts you will need for each assembly step. Doing this will save you time and effort during assembly. If possible, place the parts on cardboard or other soft surface to protect from scratching the painted surfaces.

AVERTISSEMENT : Instructions de sécurité importantes. Suivez toutes les instructions, car un assemblage incorrect peut entraîner des blessures graves.

Vérifiez qu'il ne manque aucune pièce :

Avant de commencer l'assemblage, vérifiez que vous disposez de



Unboxing & Assembly
Déballage et Assemblage
Auspacken und Montage
Uitpakken en Montage



ax4



bx4



cx4



bx4



dx4



ex6



fx4

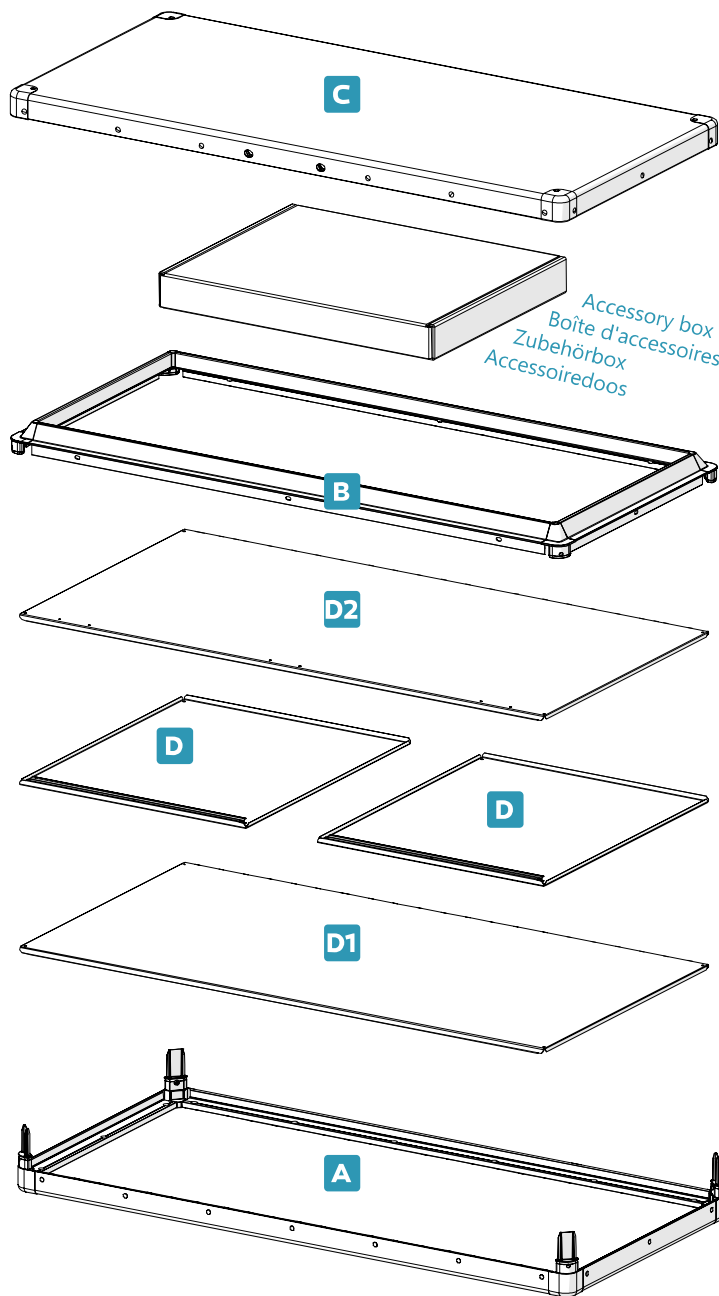

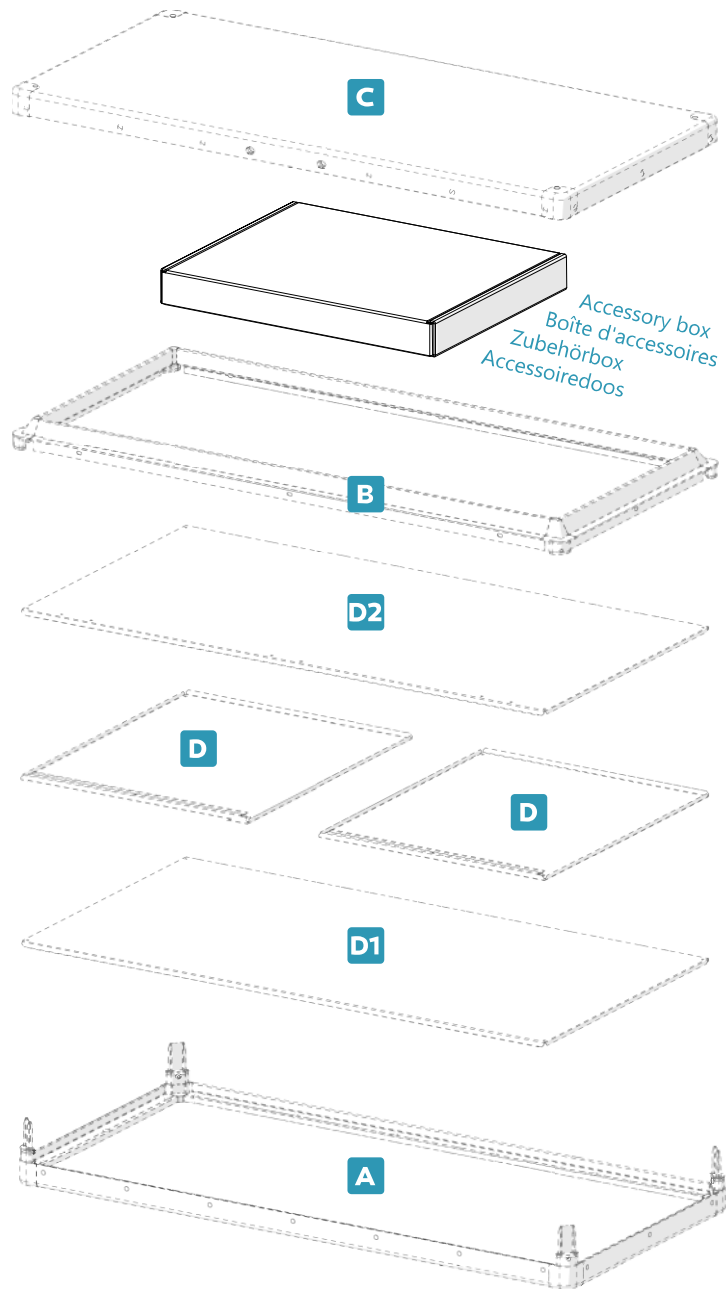

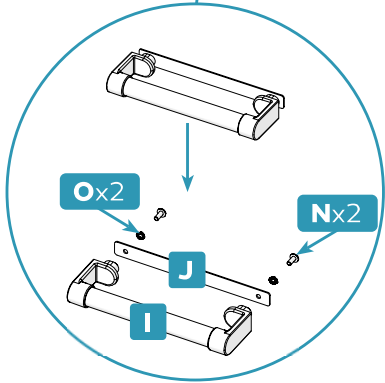
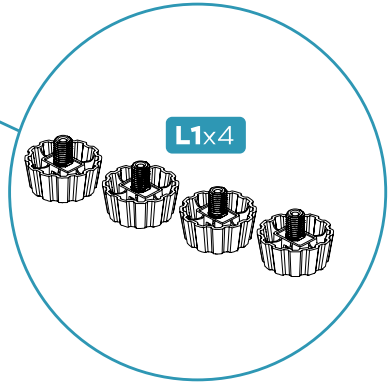
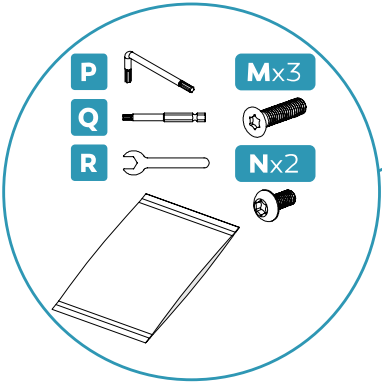
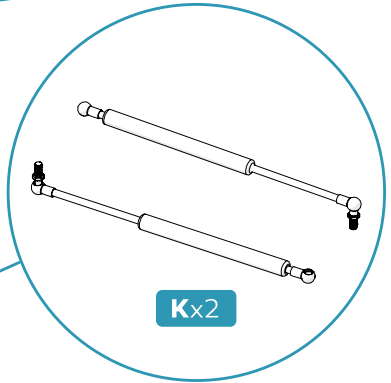
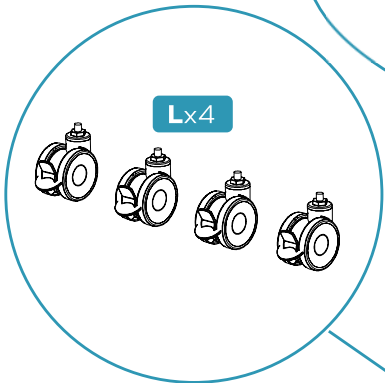
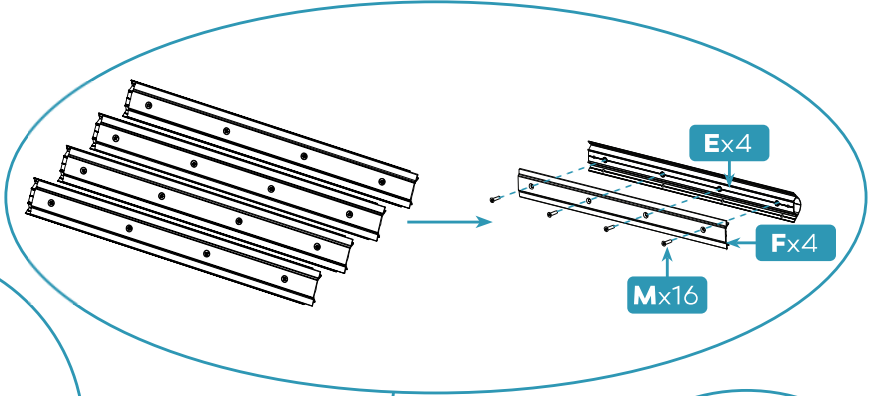
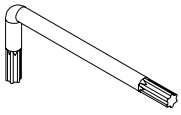

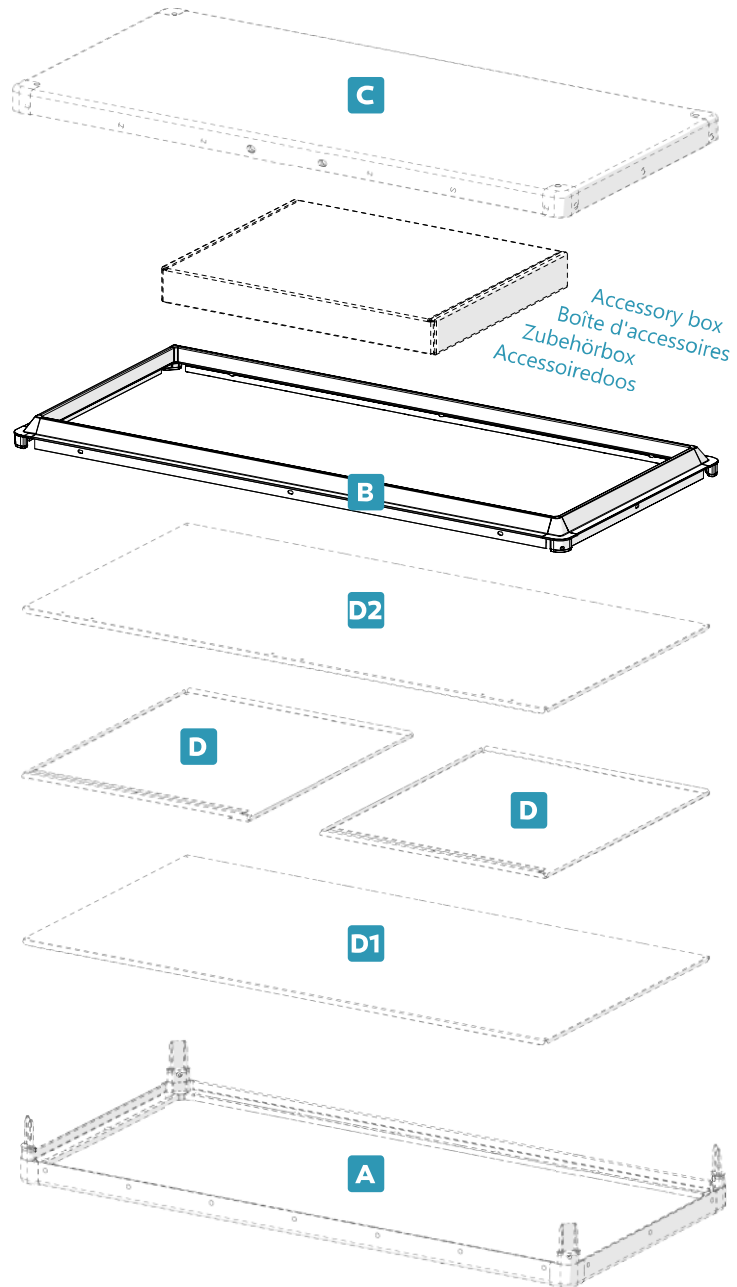

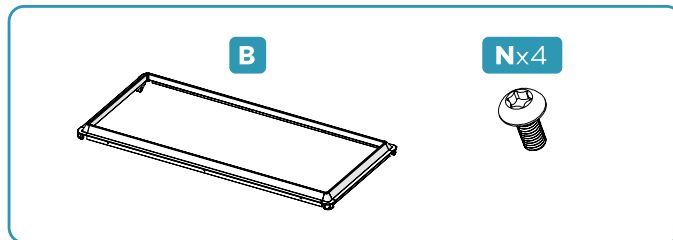
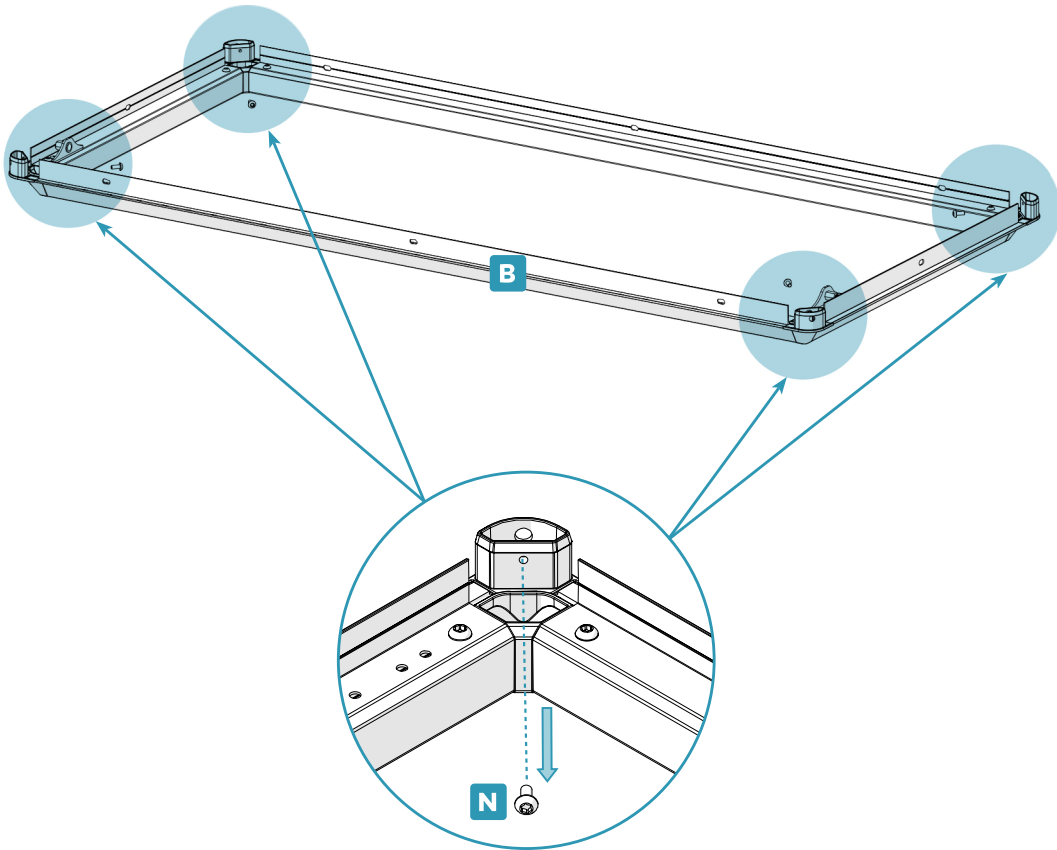
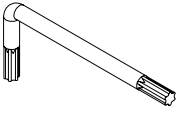

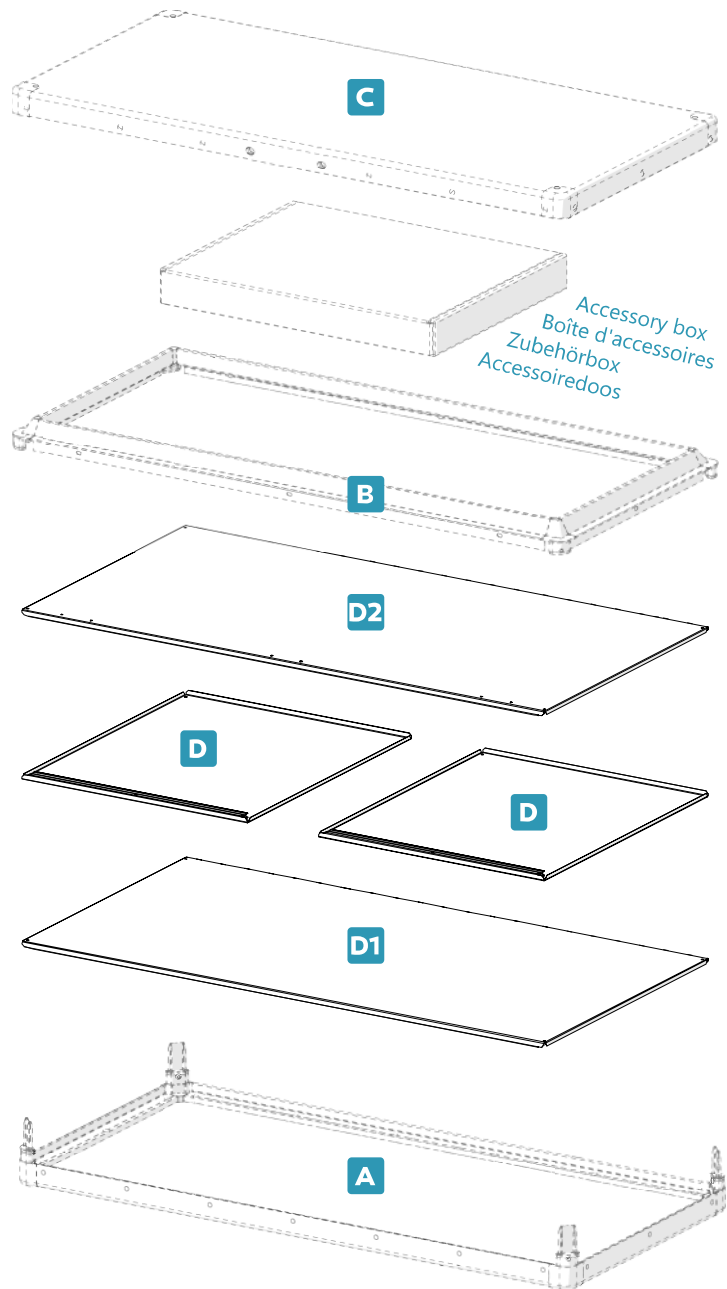

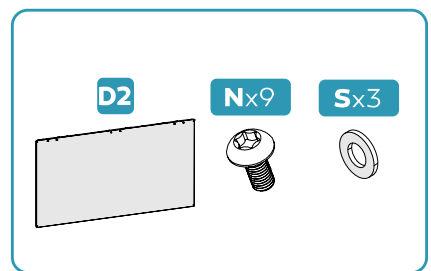
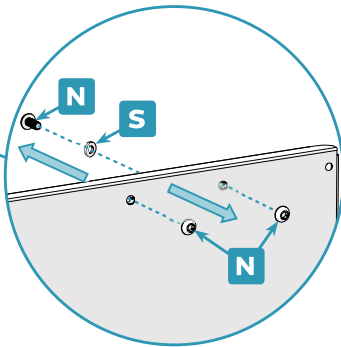
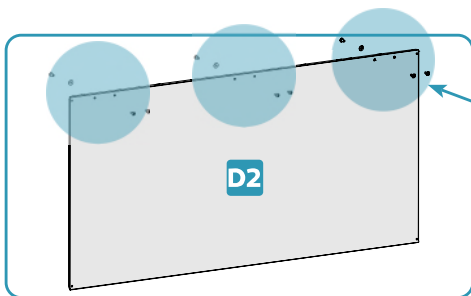
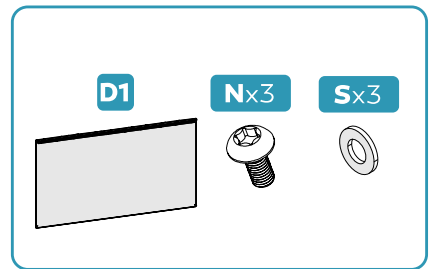
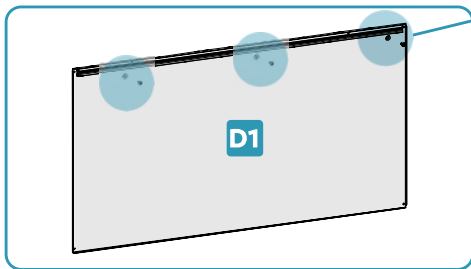
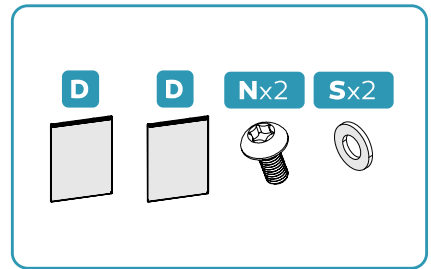
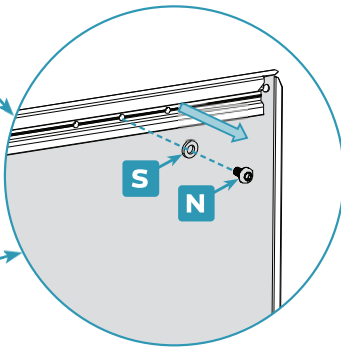
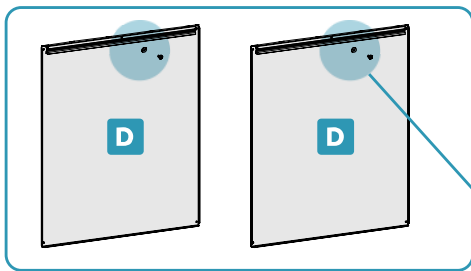
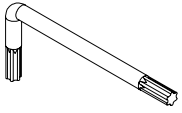

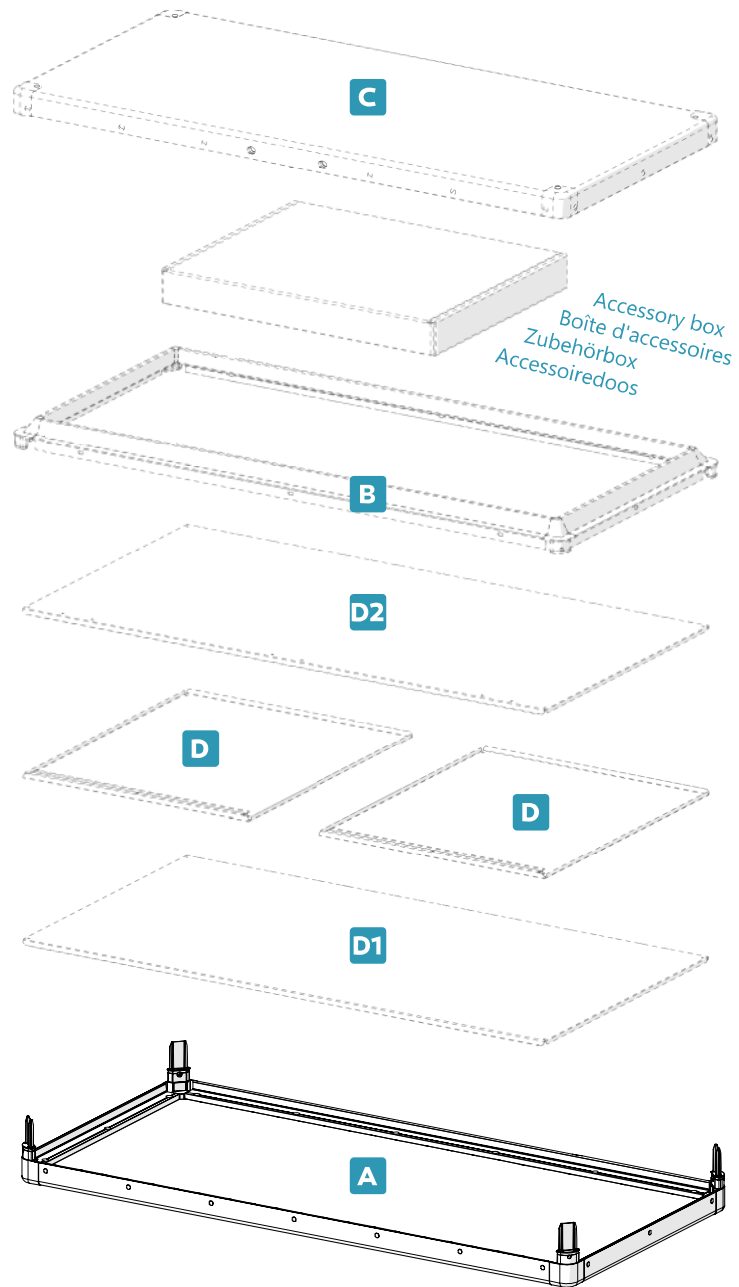

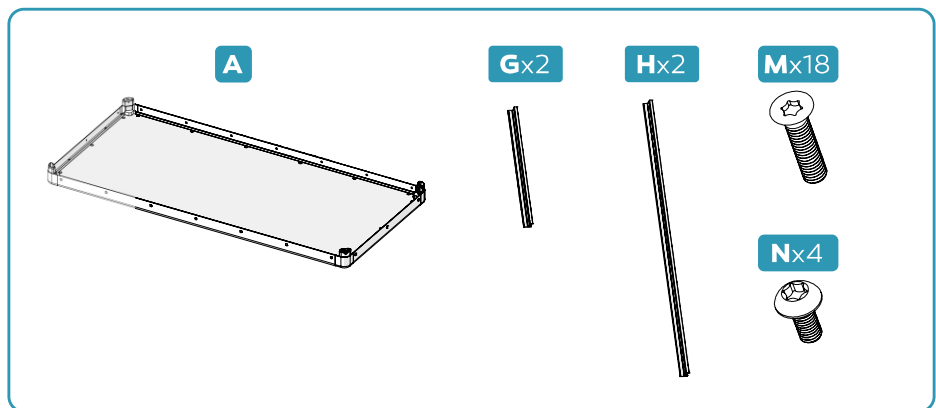
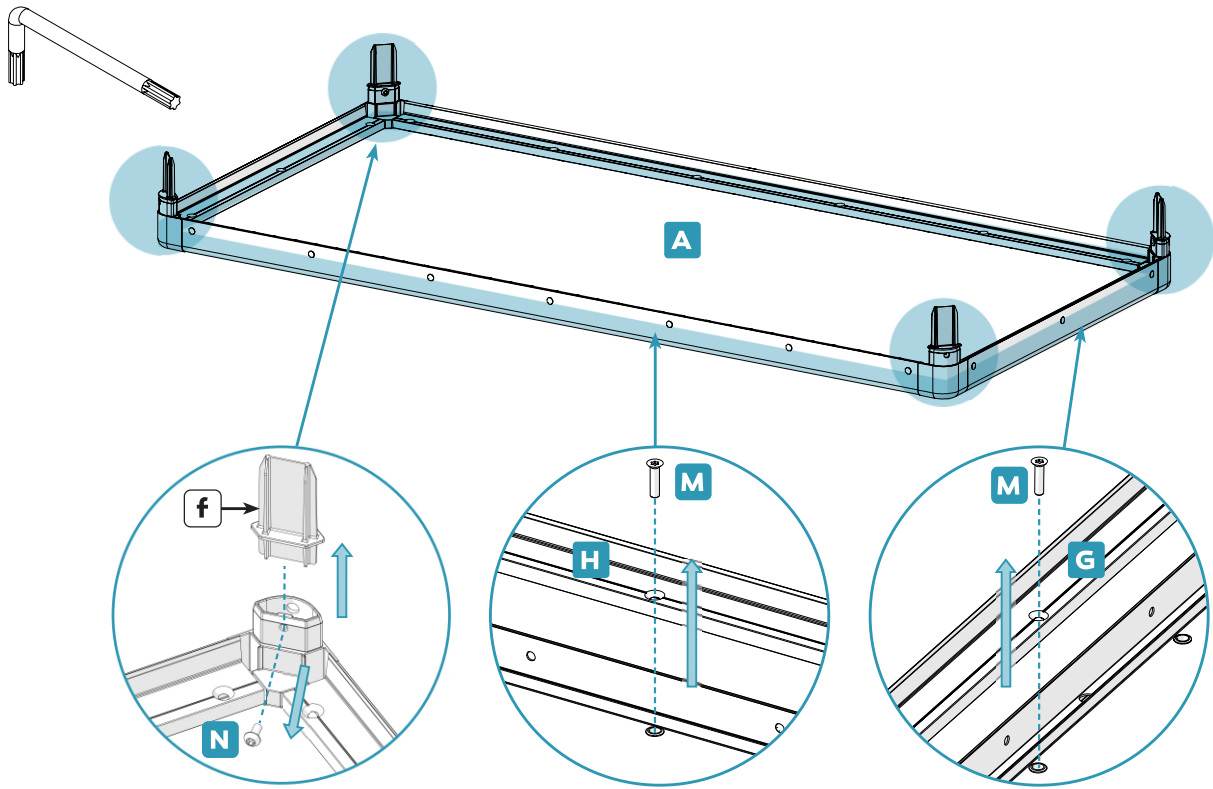

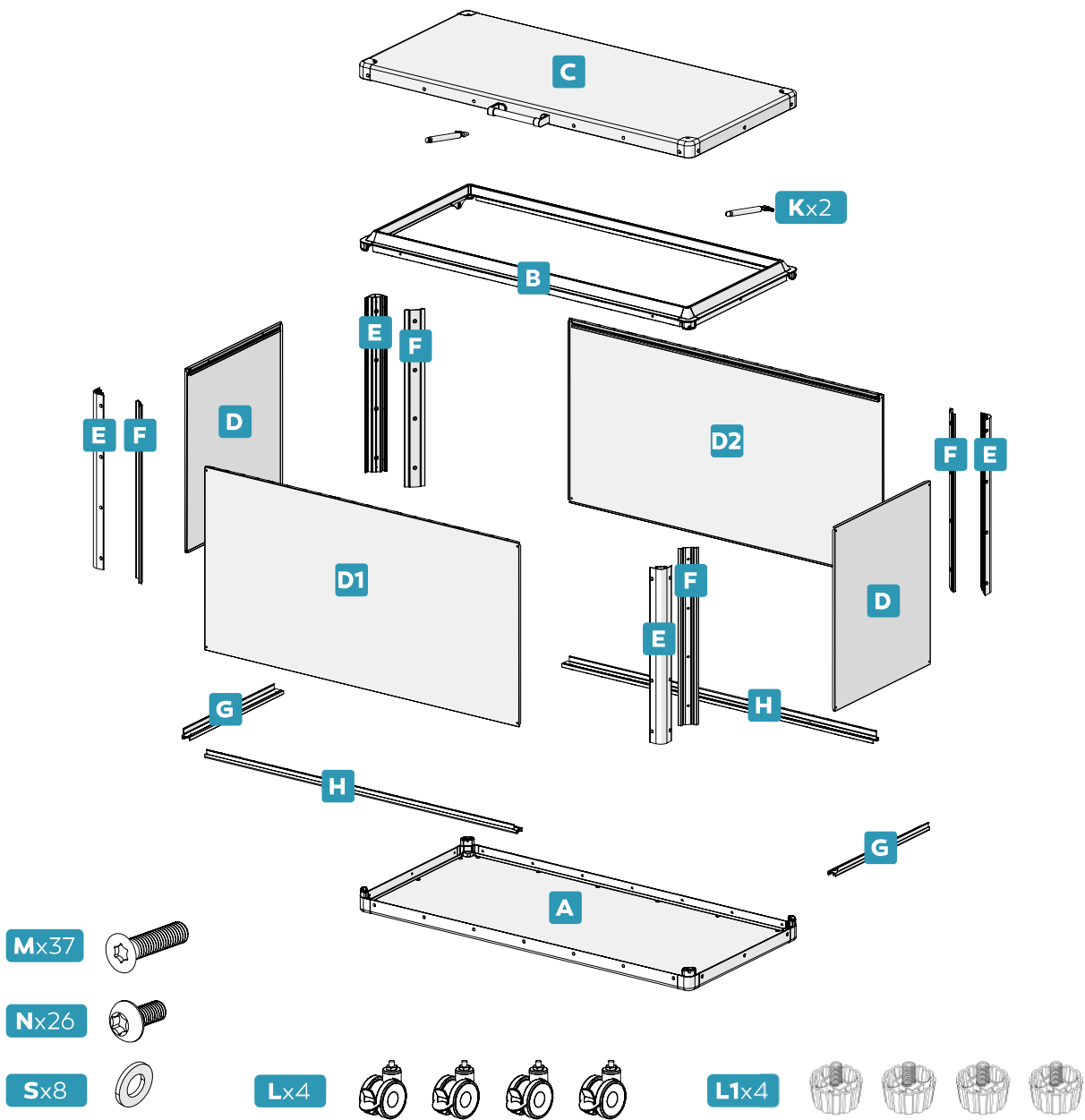

Tools required, not included.
Outils requis, non inclus.
Herramientas necesarias, no incluidas.
Benodigde gereedschappen, niet inbegrepen.



A x1

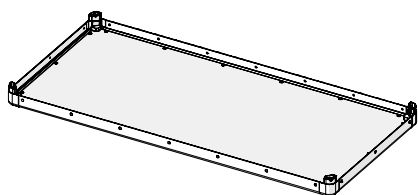

D1 x1

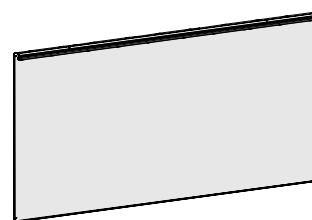

B x1

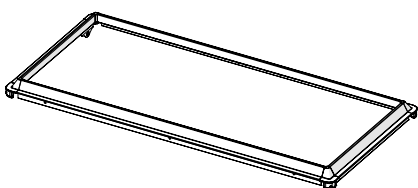

D2 x1

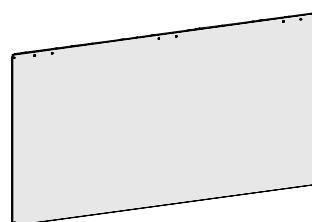

C x1

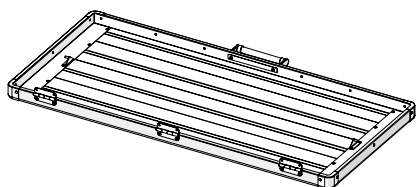

G x2



D x2

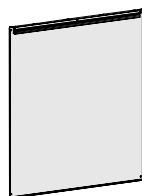

H x2



EN Accessory box
DE Zubehörbox

FR Boîte d'accessoires
NL Accessoiresdoos



E x4

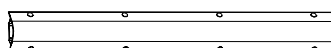

F x4

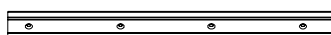

I x1

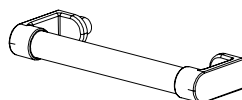

J x1



O x2



K x2

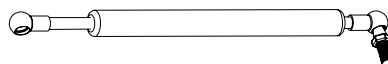



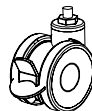

L x4

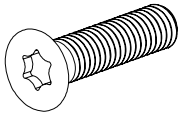

L1 x4

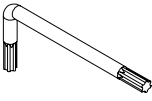
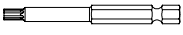
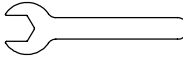

M	x34+3*		M6 x 25 mm	EN Flat head torx screw
				FR Vis Torx à tête plate
				DE Flachkopftorxschraube
				NL Platkop-torxschroef
N	x24+2*		M5 x 12 mm	EN Dome head torx screw
				FR Vis Torx à tête bombée
				DE Linsenkopftorxschraube
				NL Bolkop-torxschroef
P	x1		T25	EN Torx Allen key
				FR Clé Allen Torx
				DE Torx-Innensechskantschlüssel
				NL Torx-inbussleutel
Q	x1		T25	EN Torx bit
				FR Embout Torx
				DE Torx-Bit
				NL Torx-bit
R	x1		12 mm	EN Wrench
				FR Clé
				DE Schraubenschlüssel
				NL Steeksleutel
S	x8		M5	EN Washer
				FR Rondelle
				DE Unterlegscheibe
				NL Rondelle

*Extra spare parts included / *Pièces de rechange supplémentaires incluses / *Zusätzliche Ersatzteile enthalten / *Extra reserveonderdelen inbegrepen

EN ASSEMBLY

FR ASSEMBLAGE

DE MONTAGE

NL MONTAGE

01

A x1  L x4  or L1 x4 

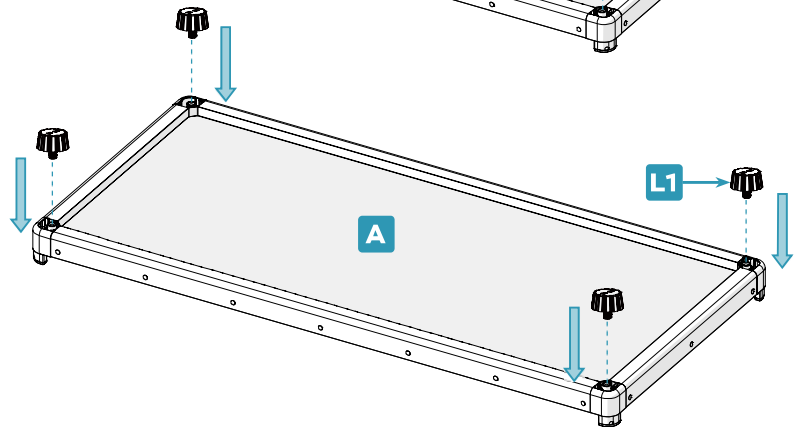
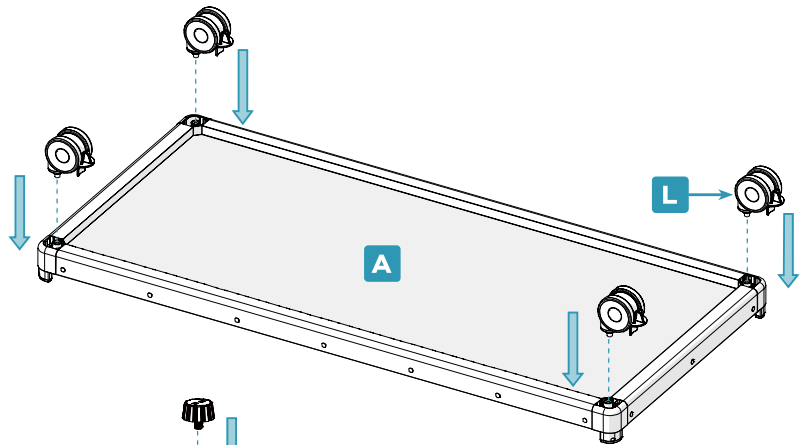
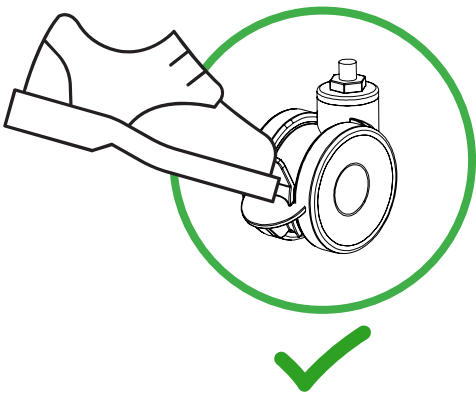

02

E x 4 

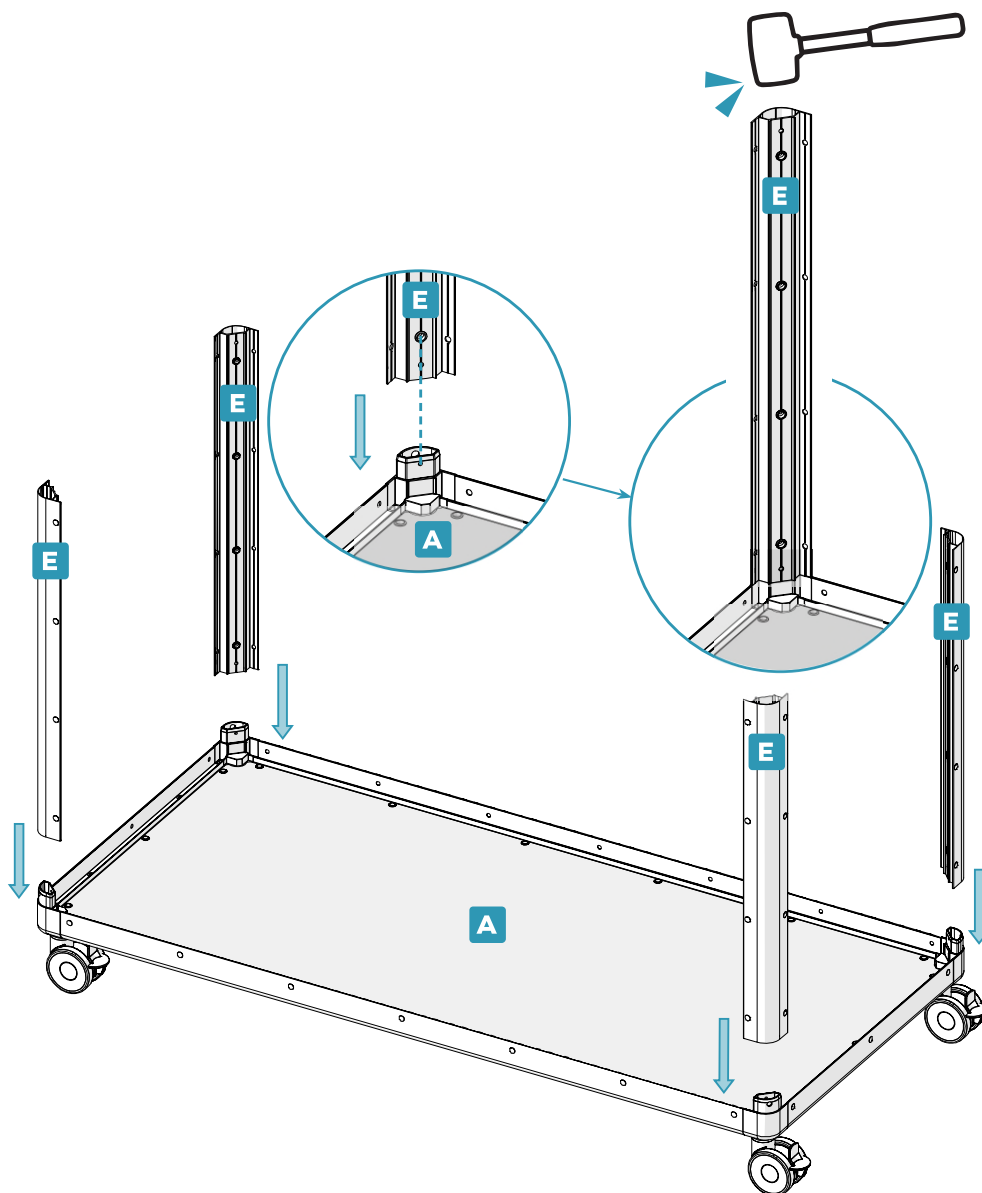

03

N x 4



P

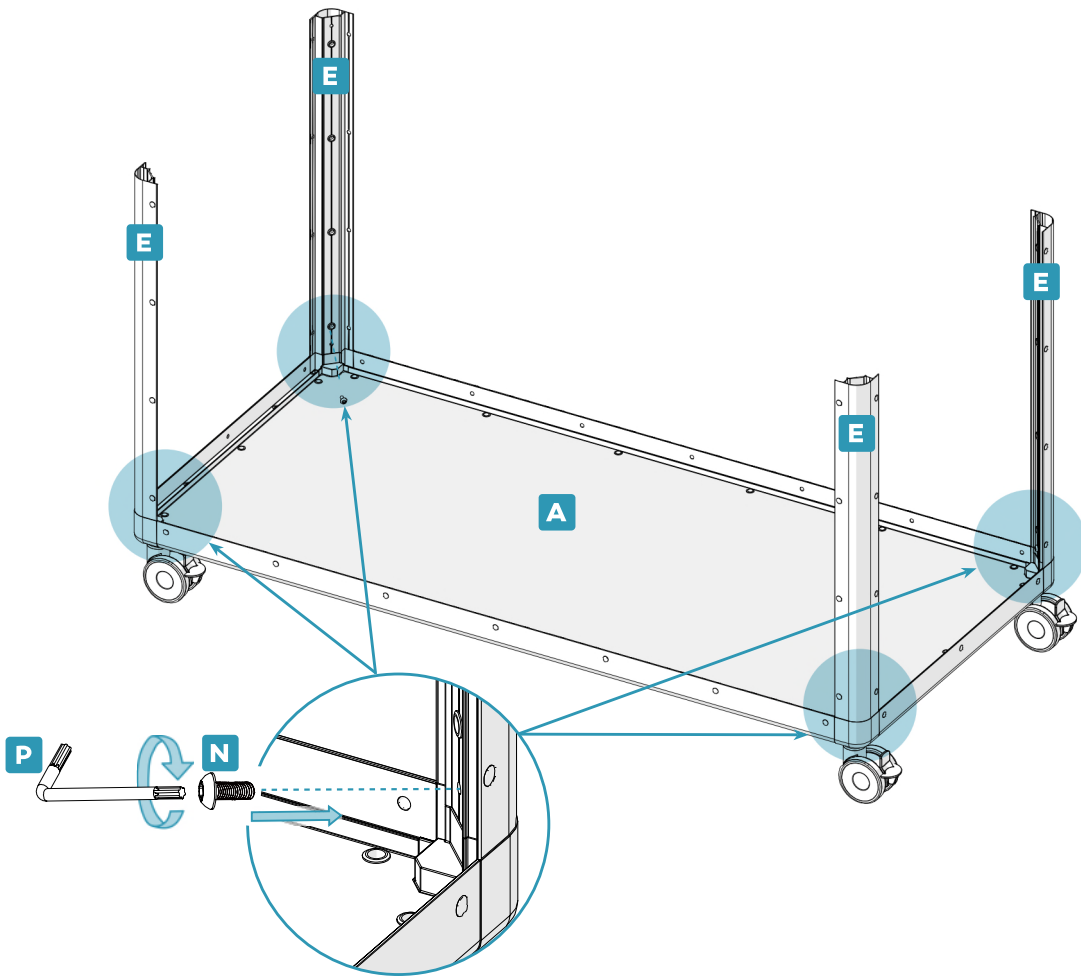

04

D x1

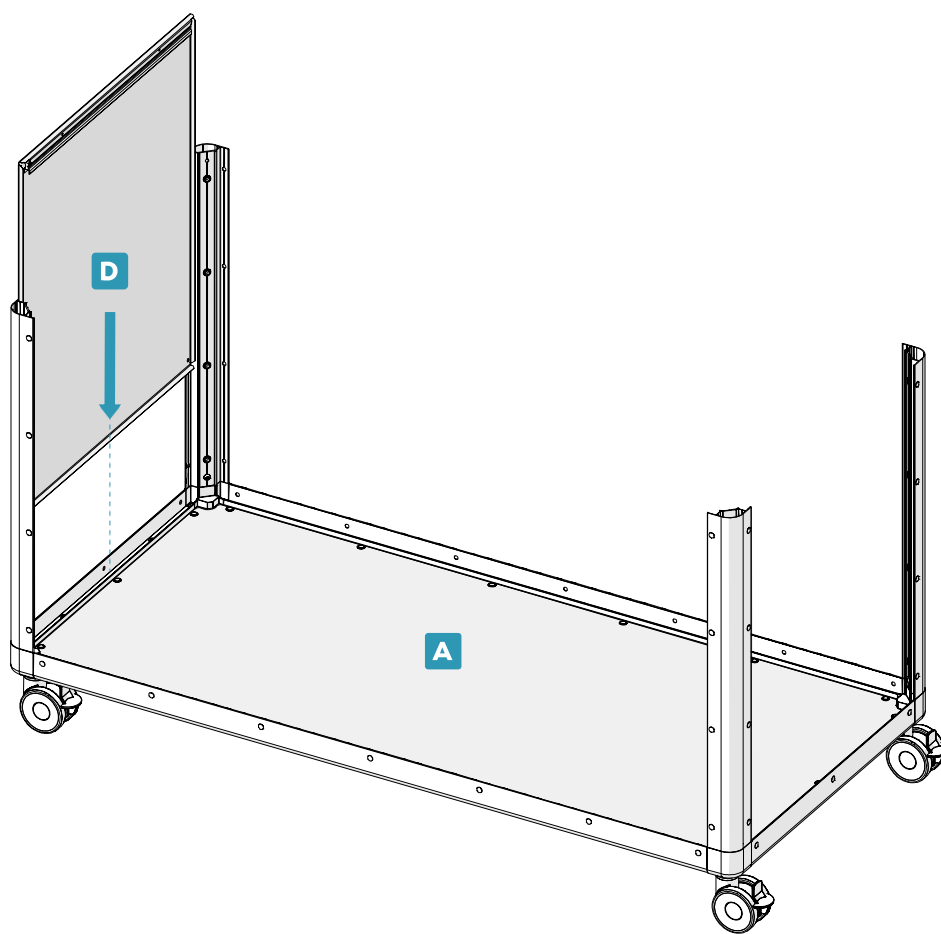

05

D2 x1

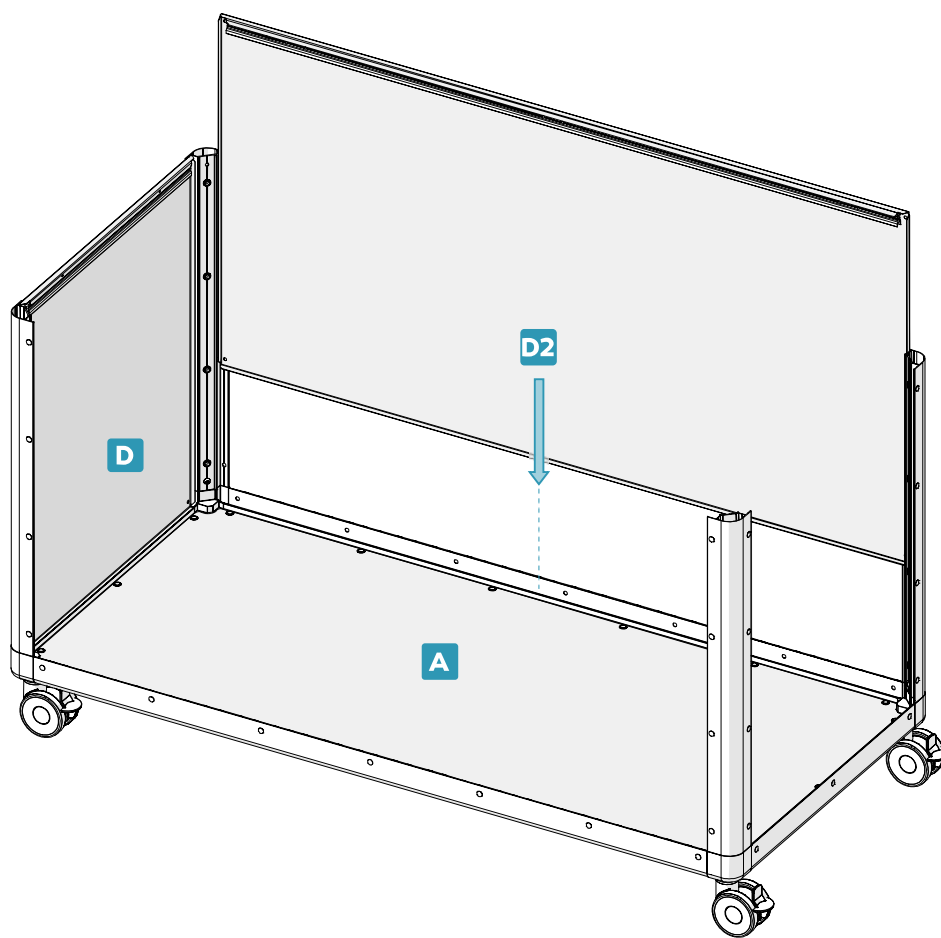
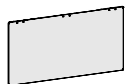

06

G x1



H x1

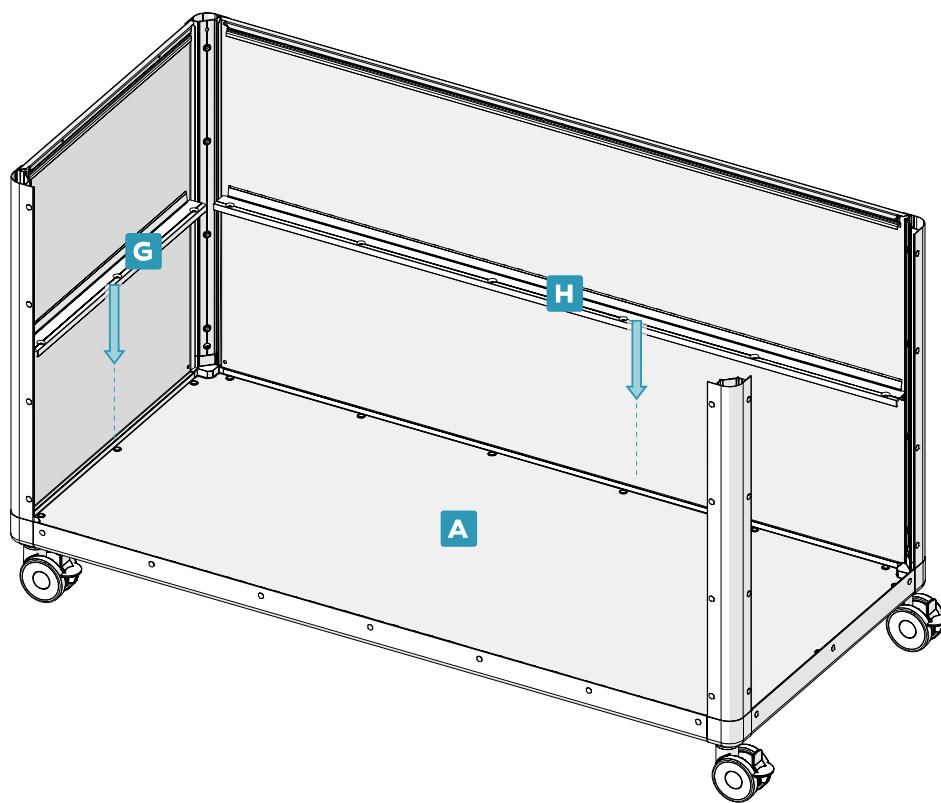

07

M x9

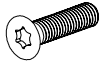

P

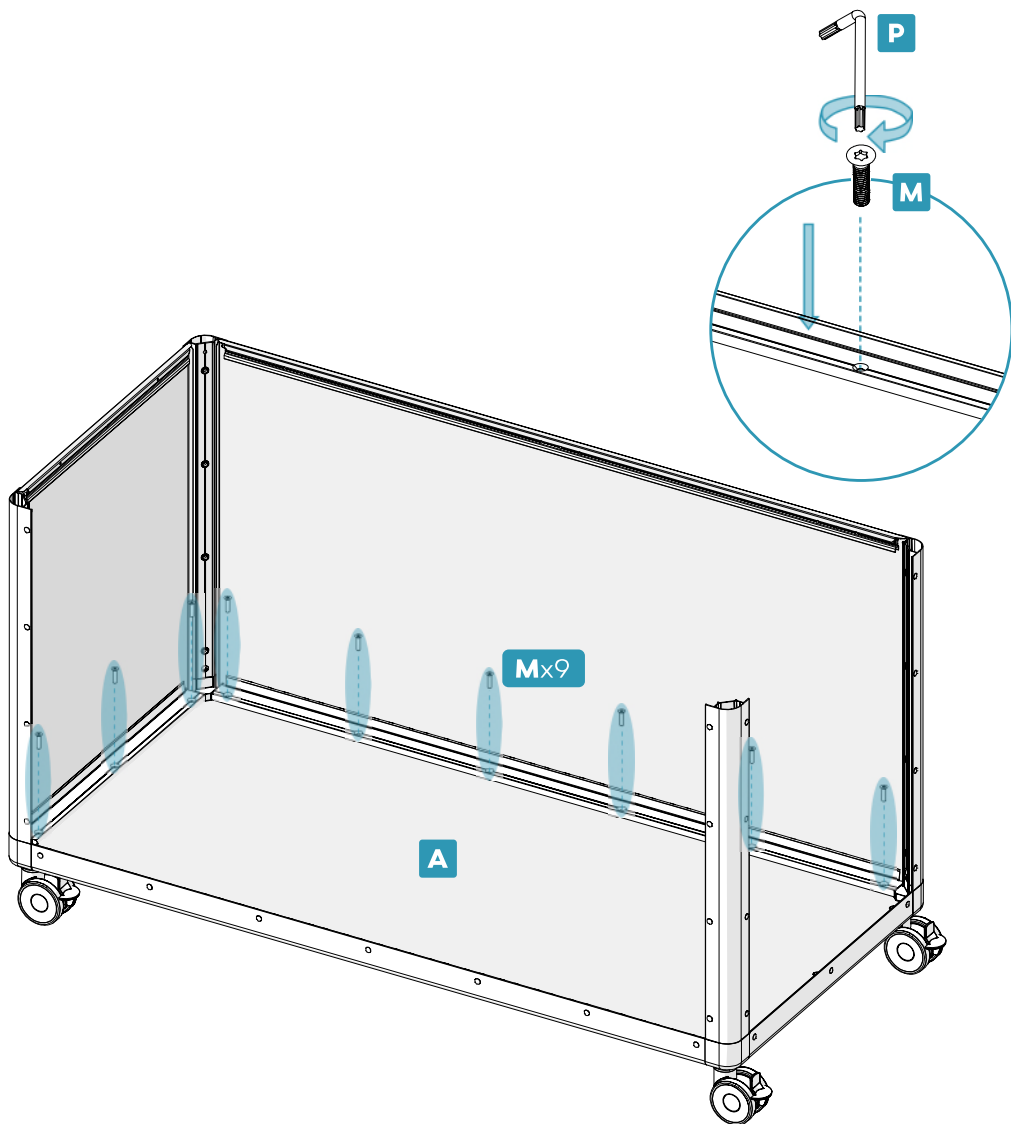

08

D x1 

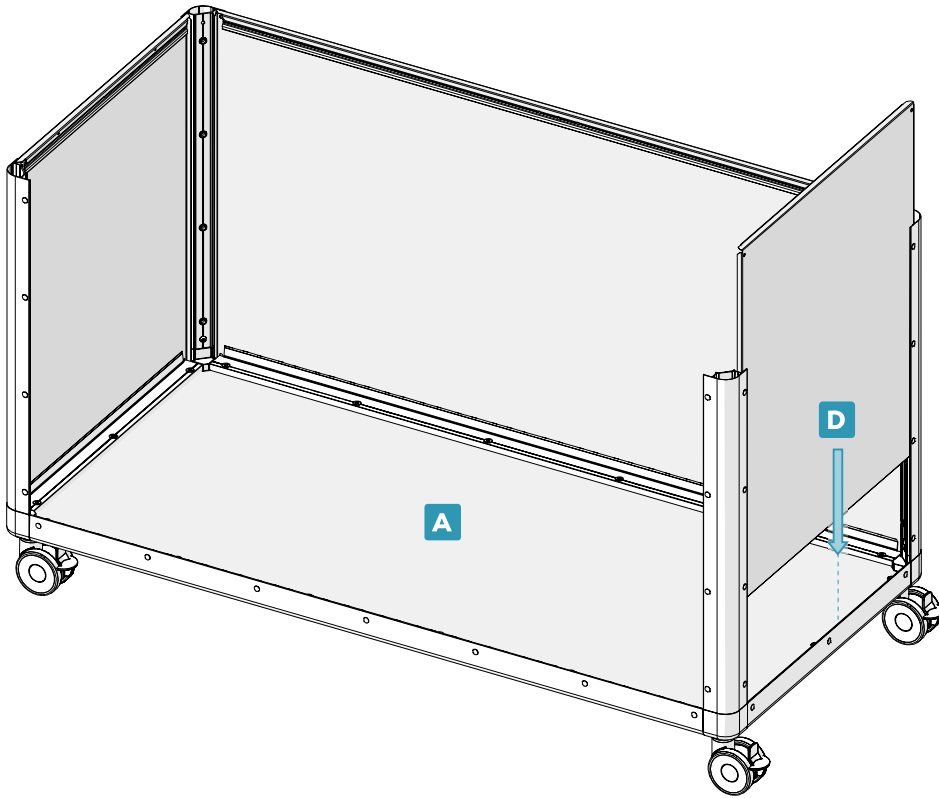

09

D1 x1

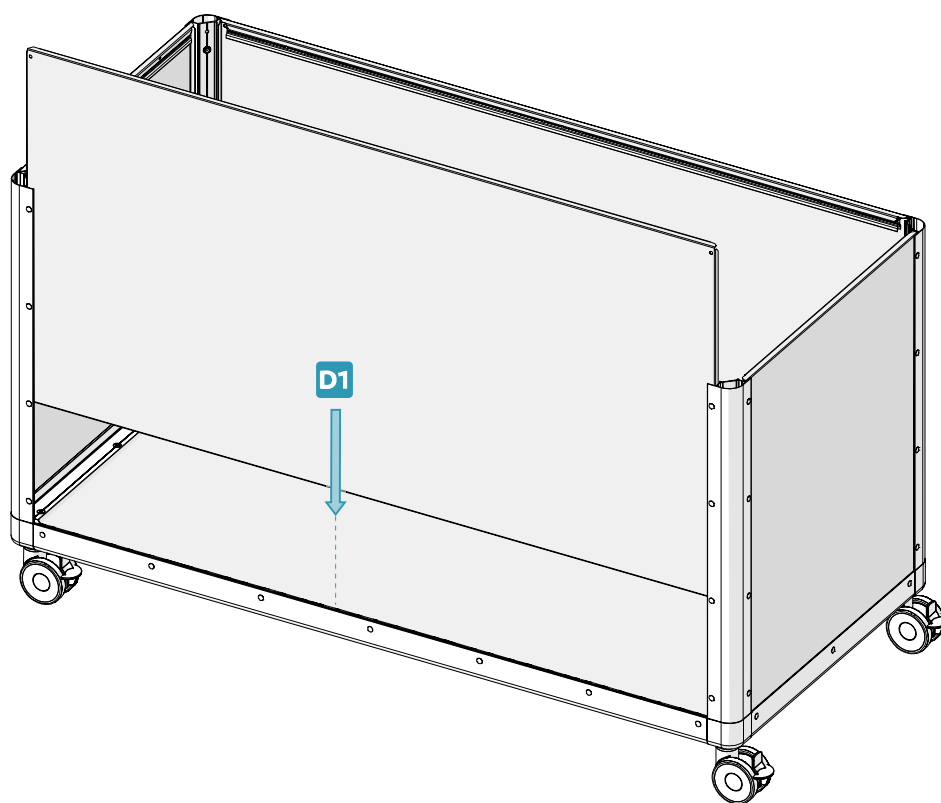

10

G x1  **H** x1 

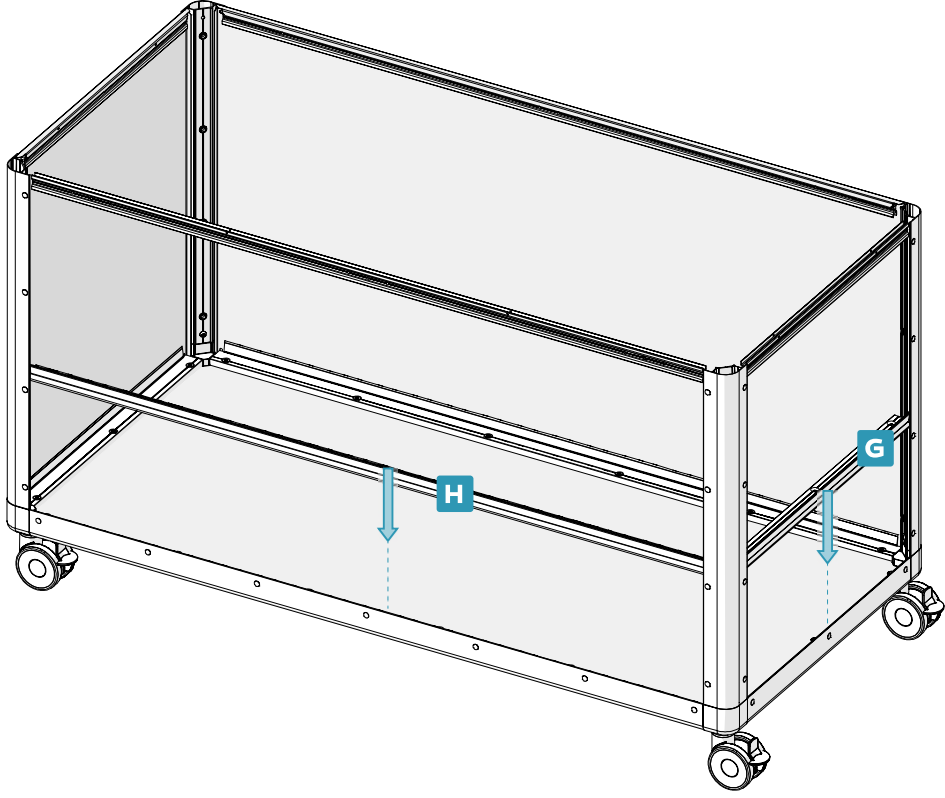

11

M x9

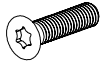

P

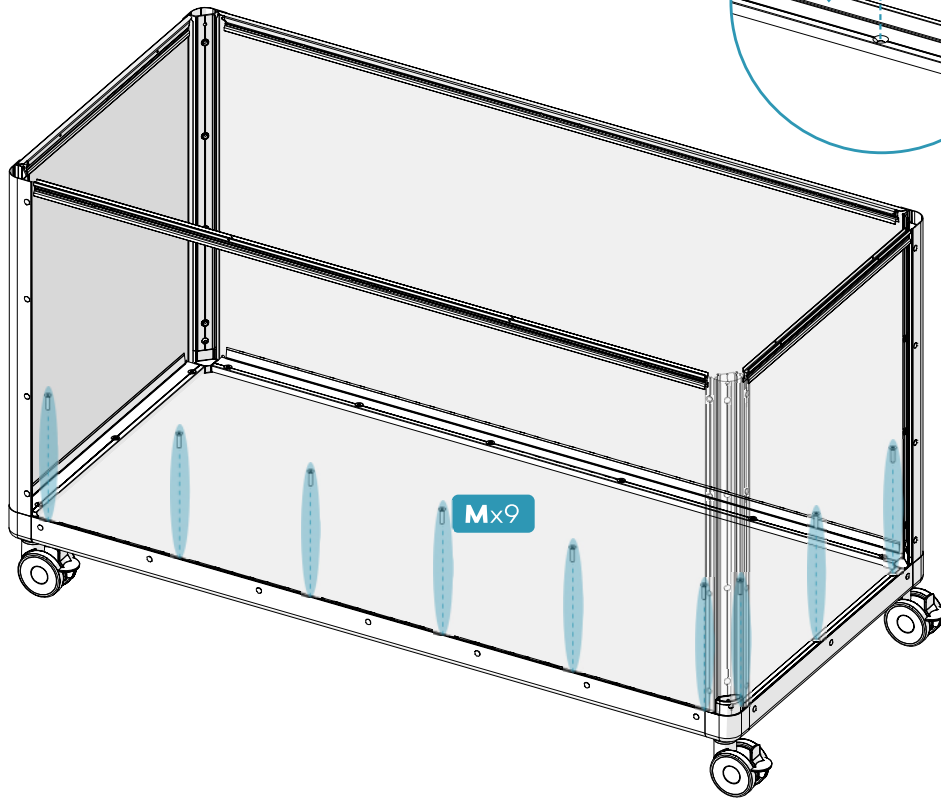
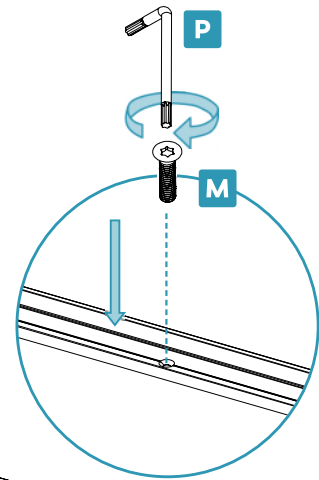

12

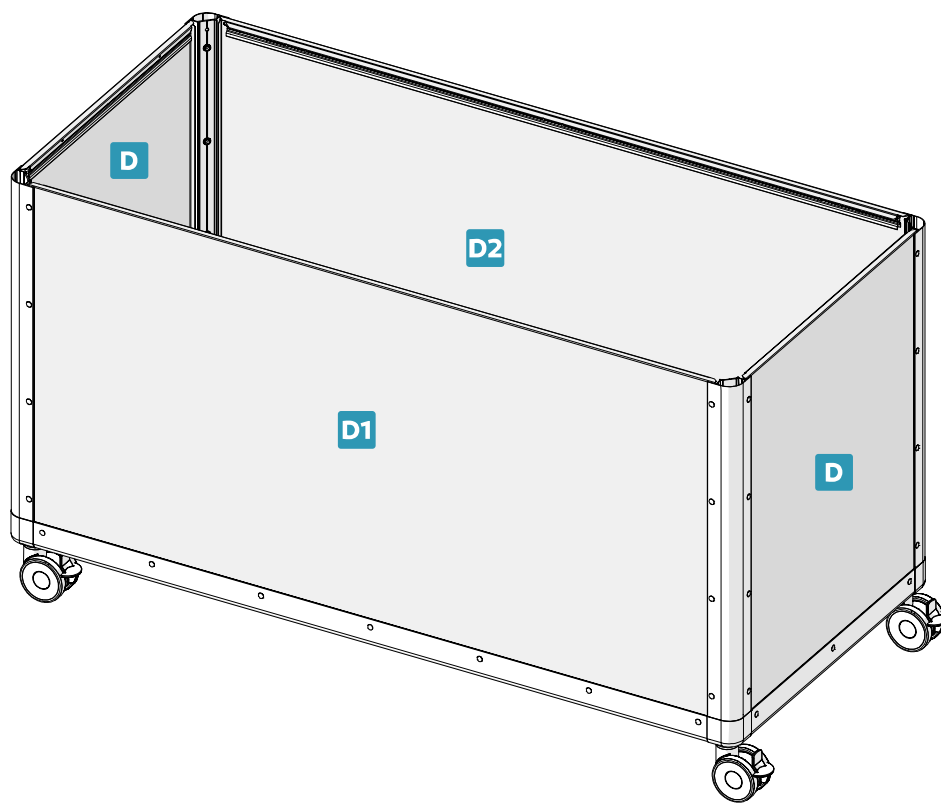

13

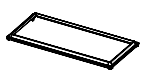
B x1 

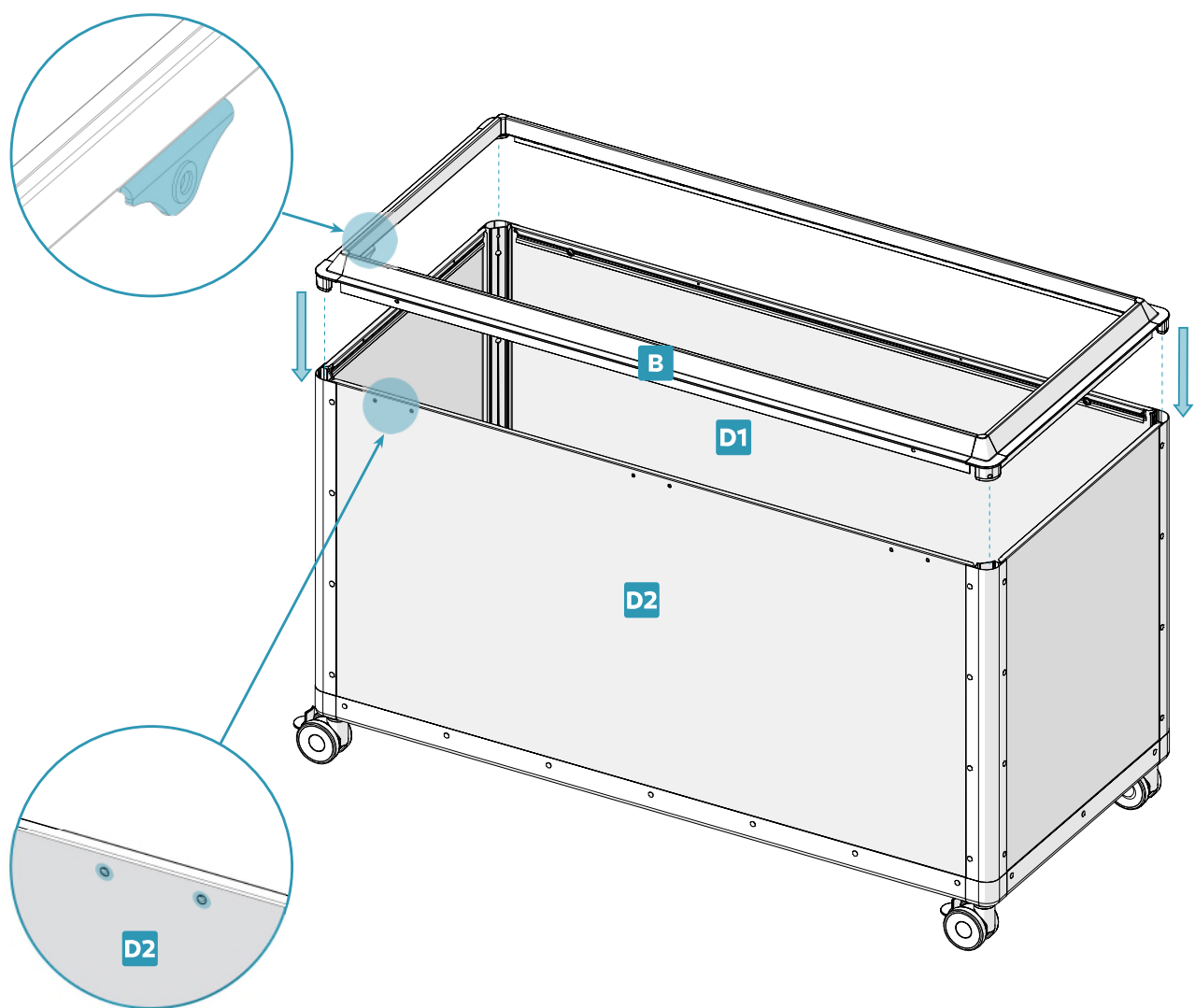

14

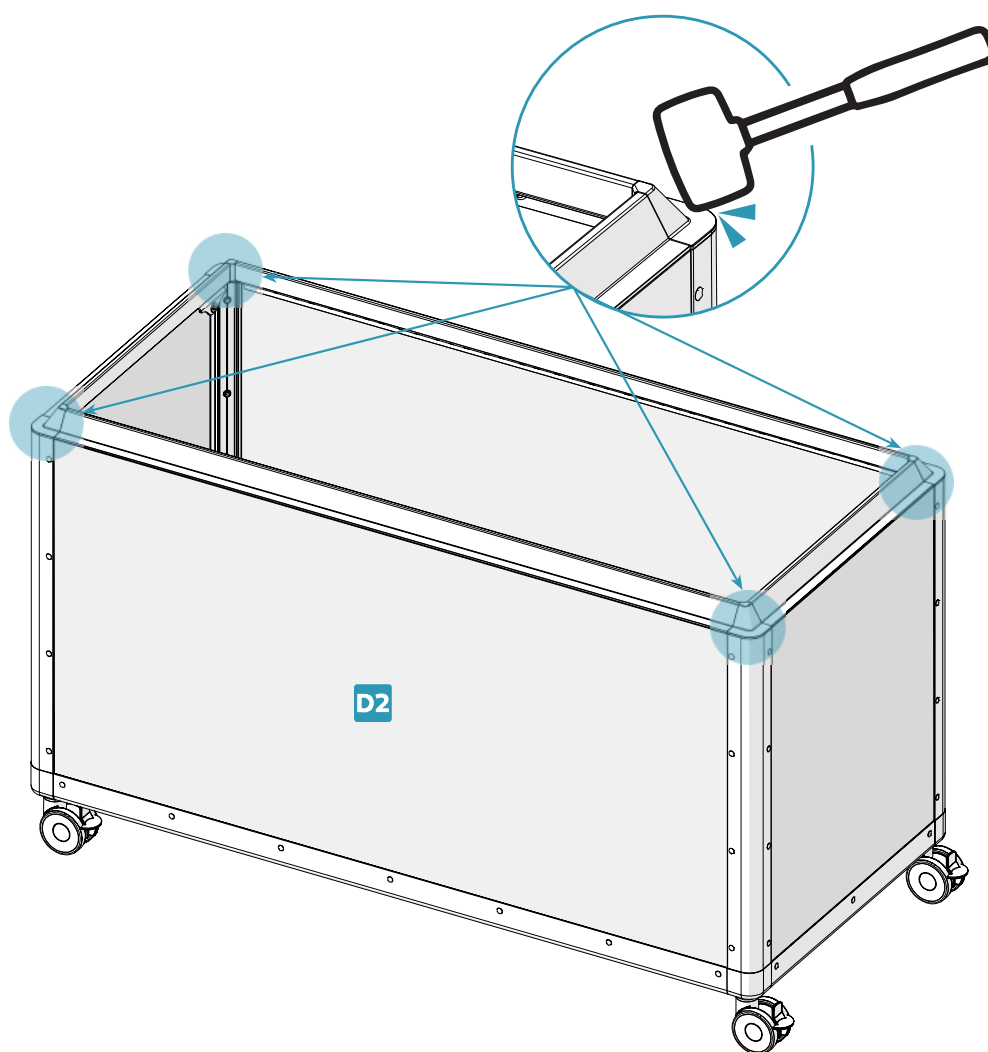

15

N x4 

P 

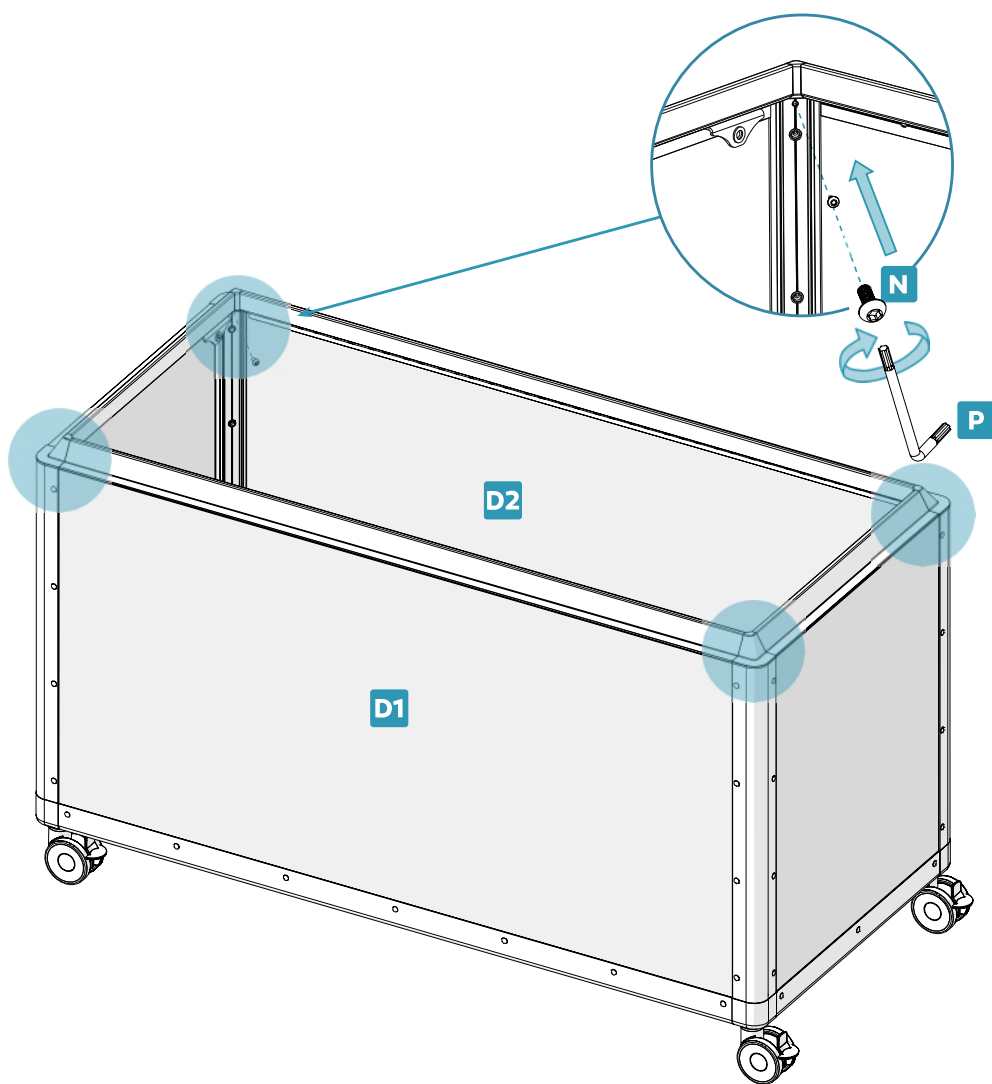

16

N x8



S x8



P

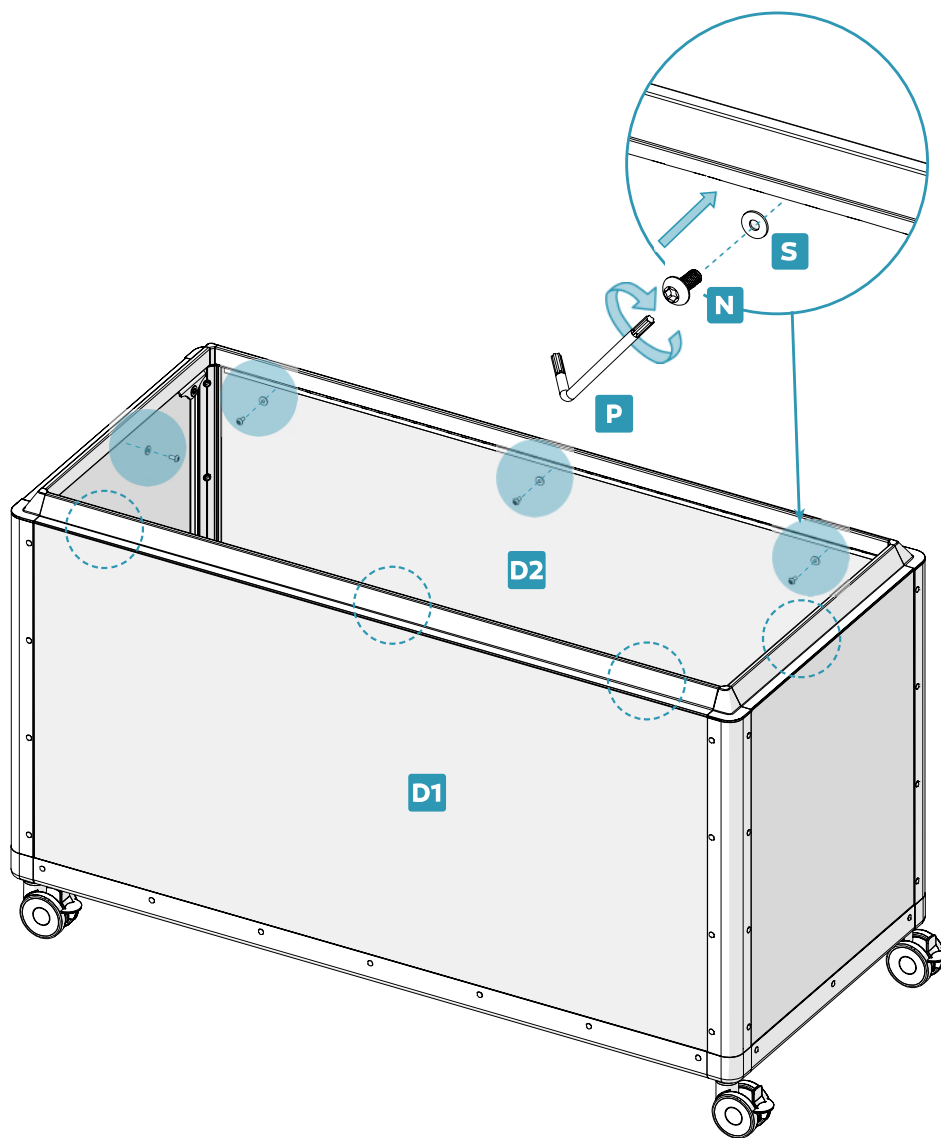

17

F x4 

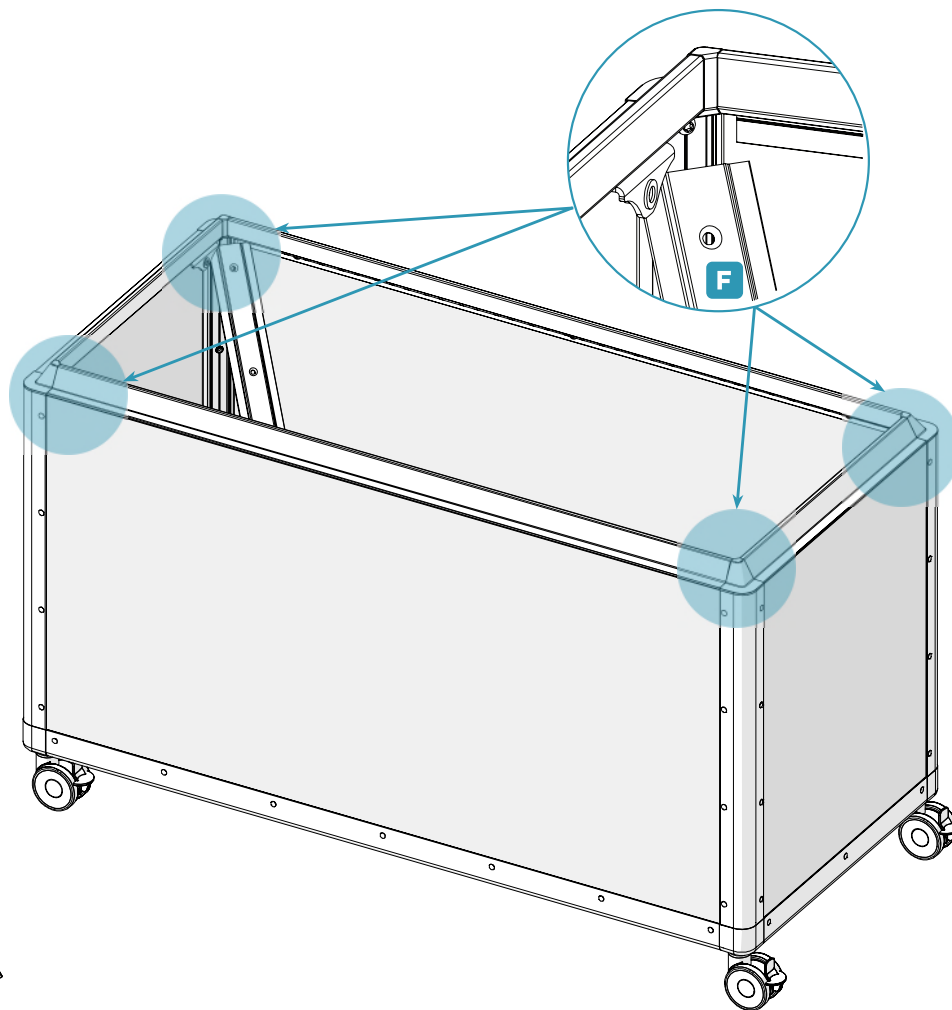
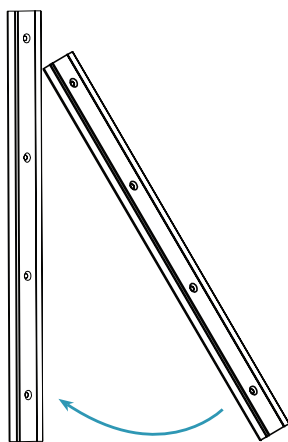
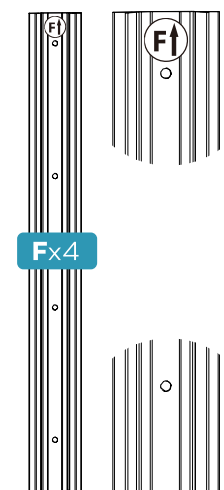

18

M x 16 

P 

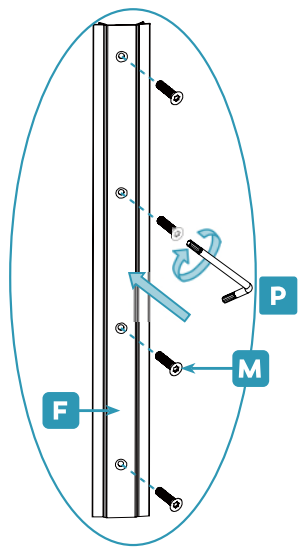
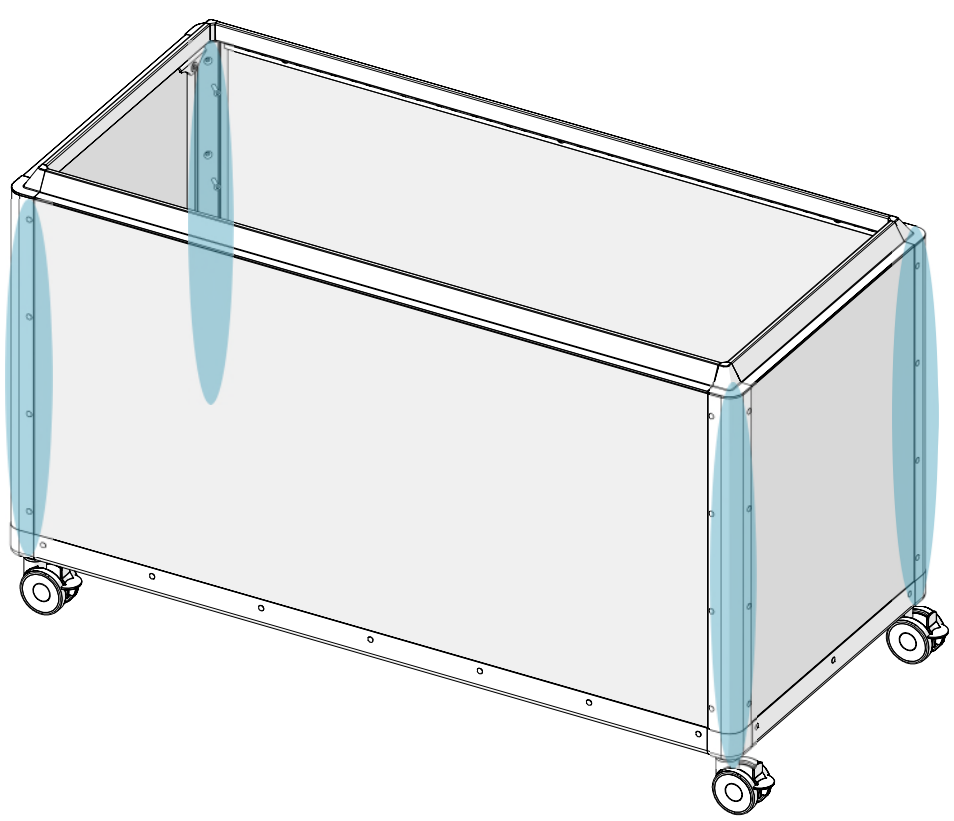

19

- C** x1 
- I** x1 
- J** x1 
- O** x2 
- N** x2 
- P** 

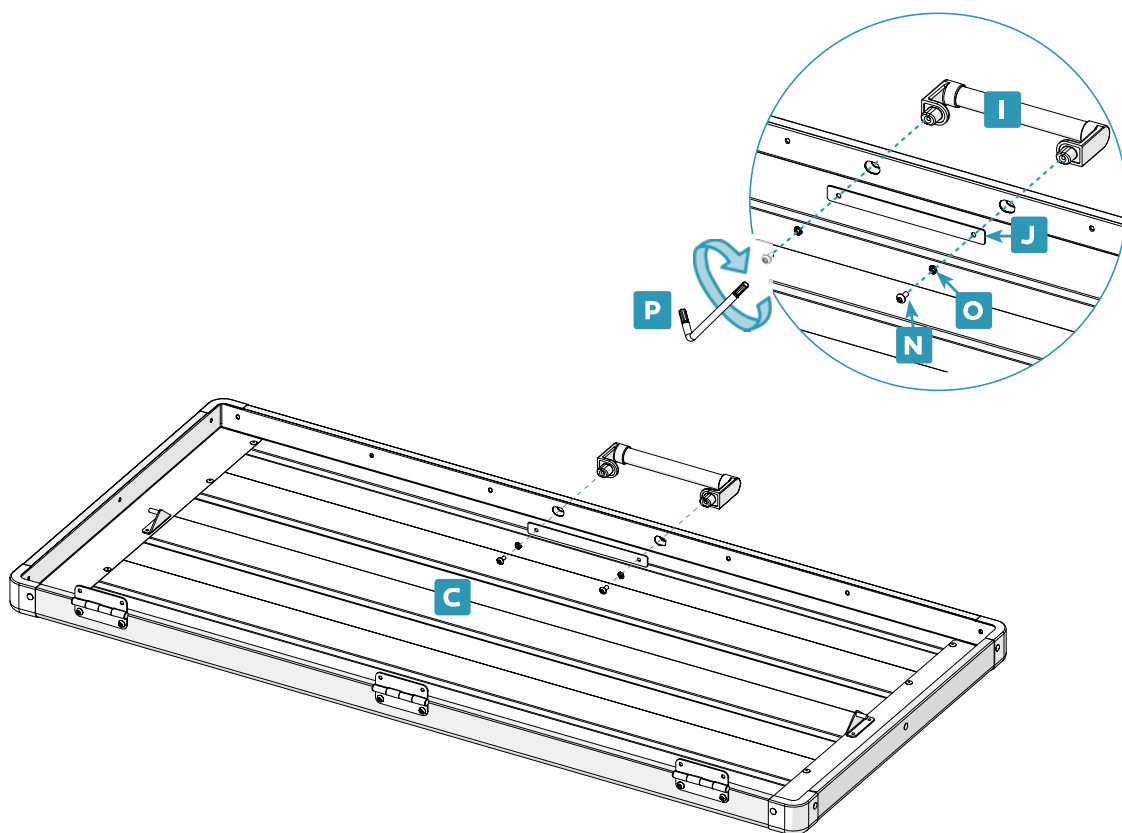

20

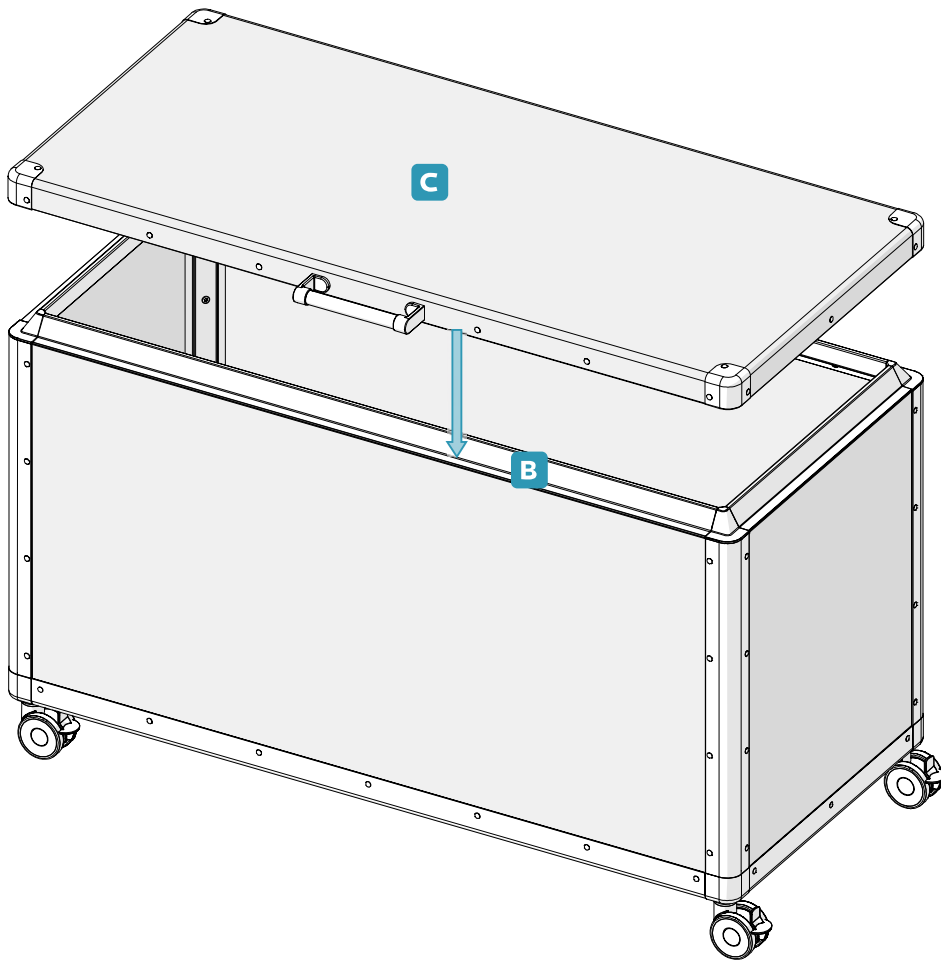

21

N x 4 

P 

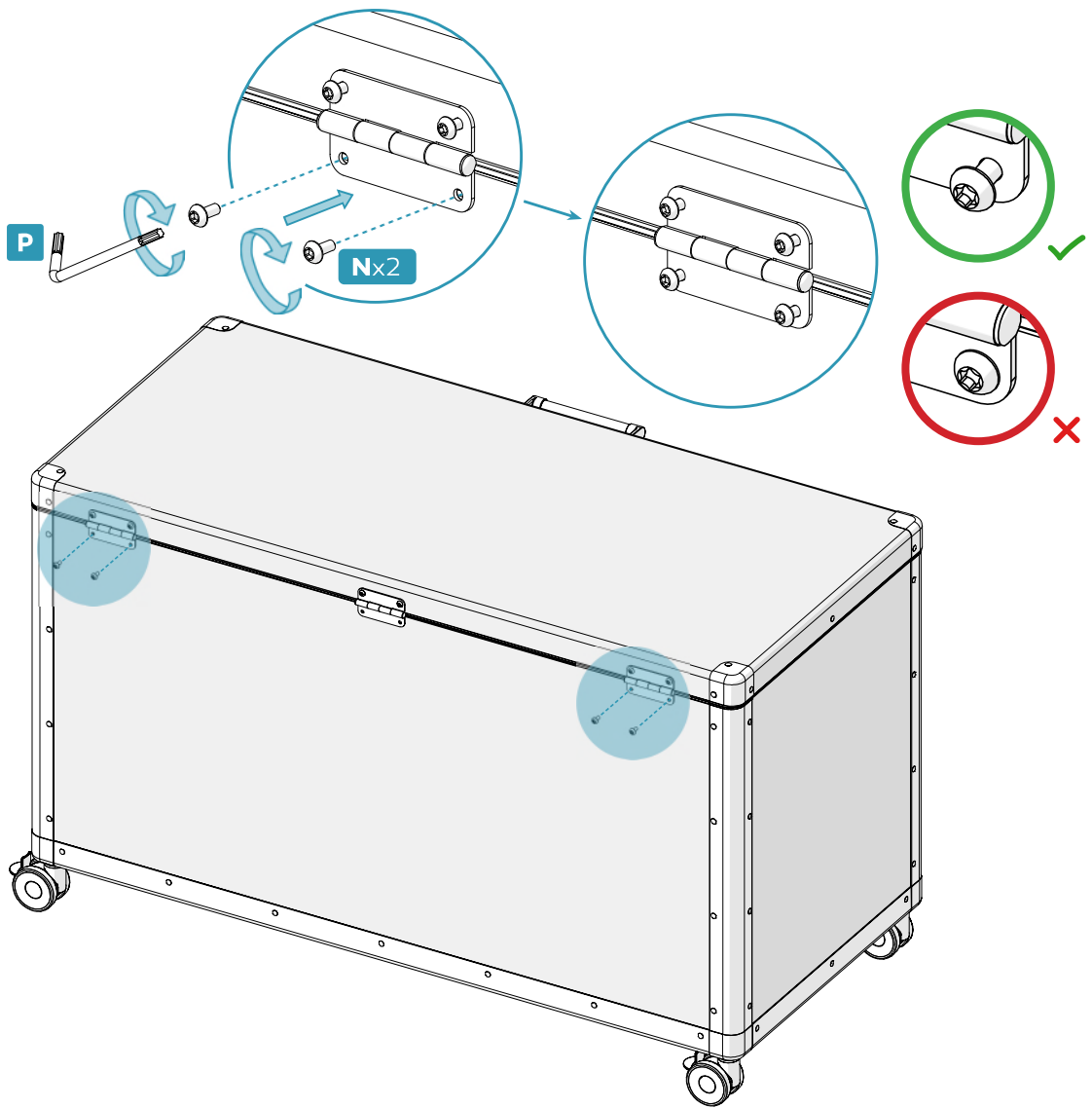

22

N x2 

P 

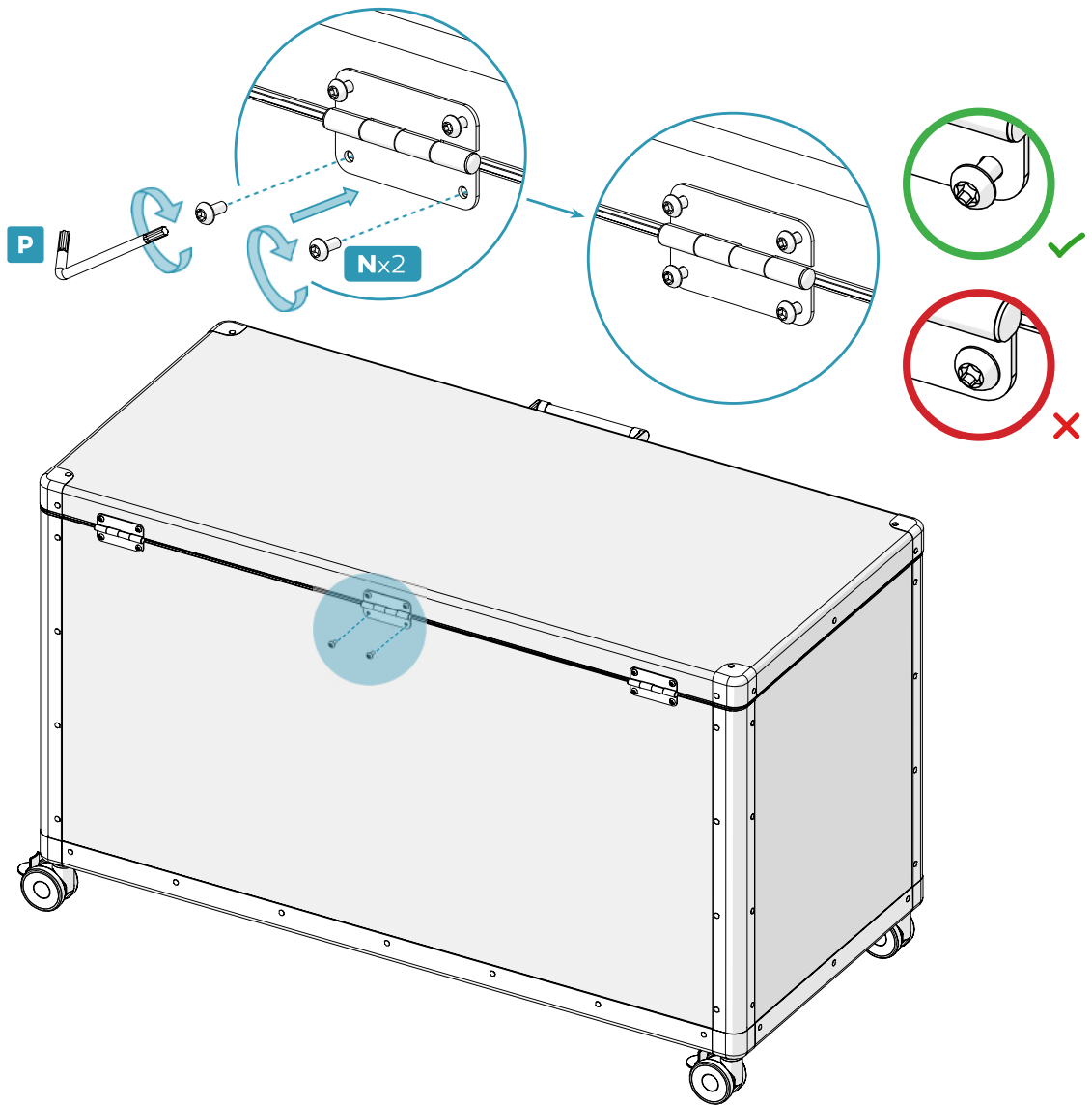

23

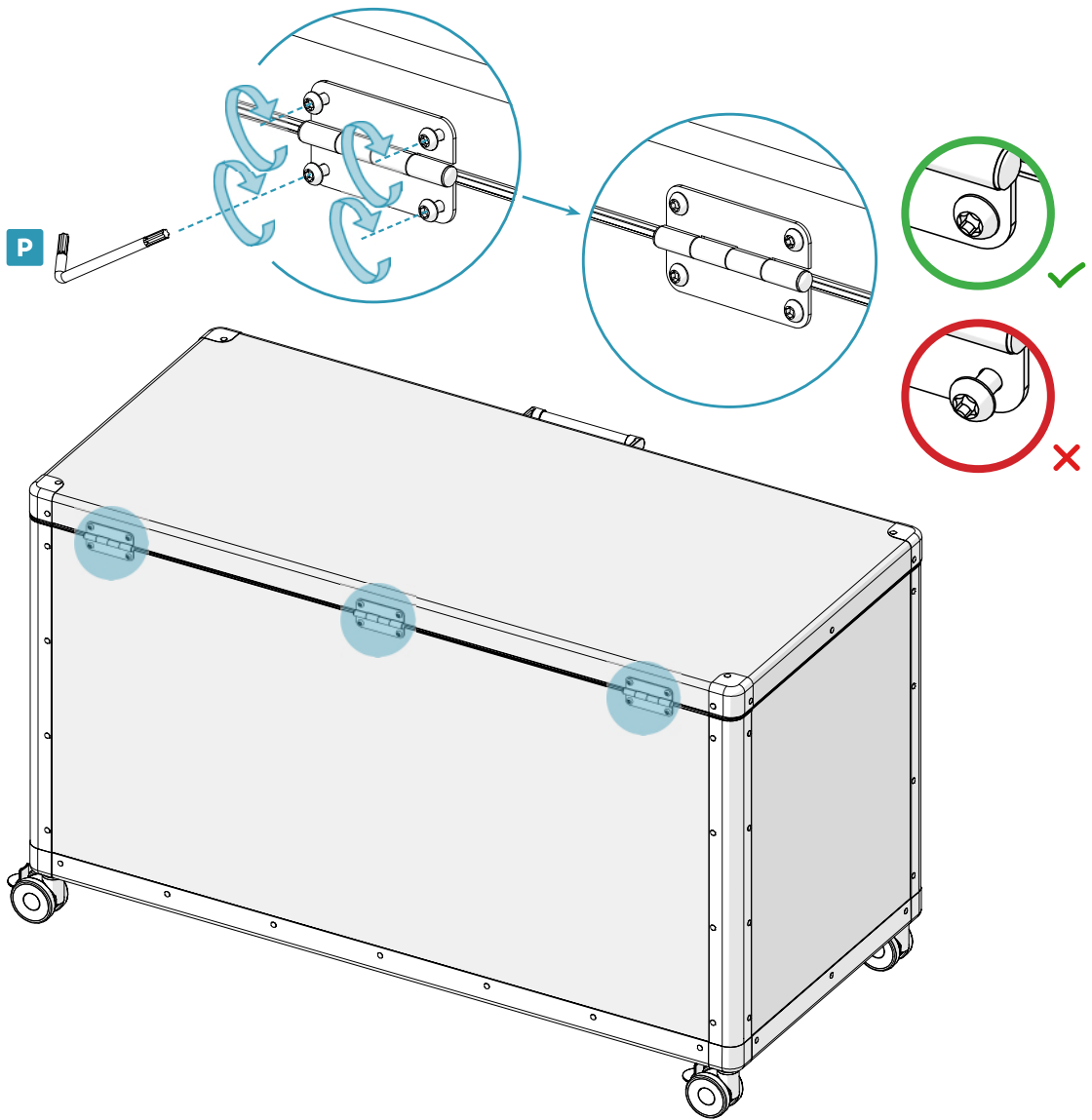

24

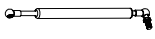
K x2 

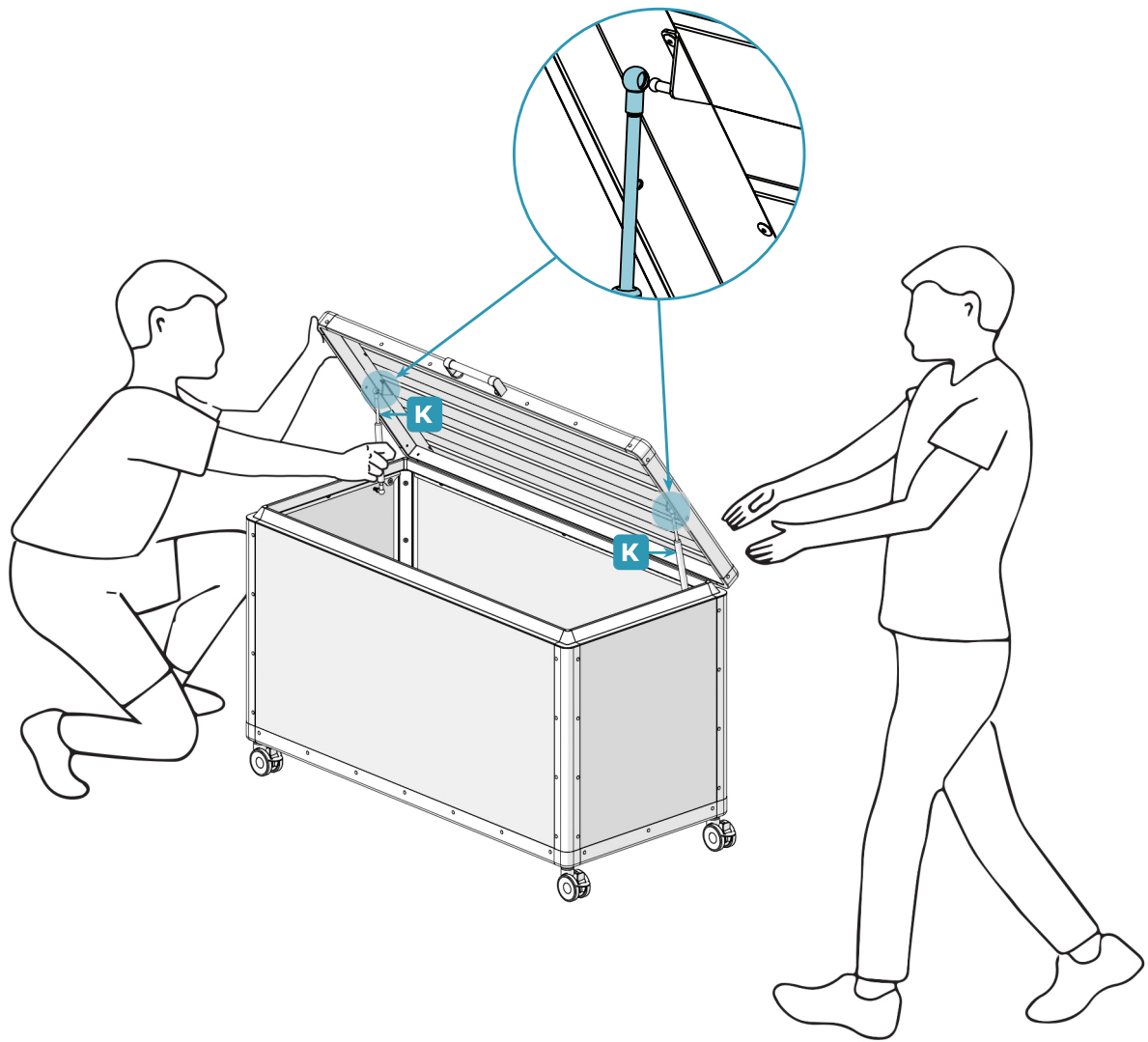

25

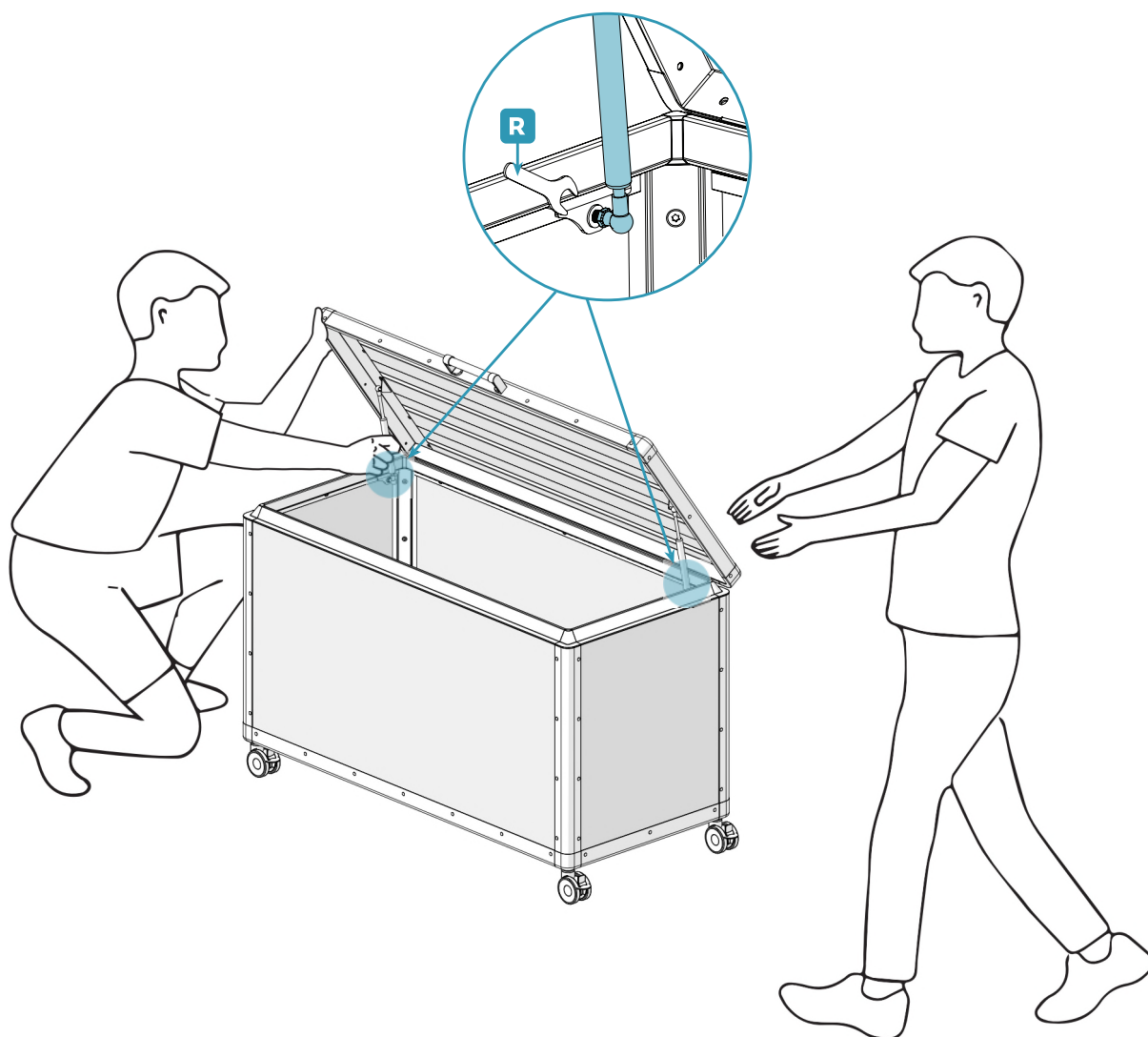
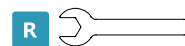

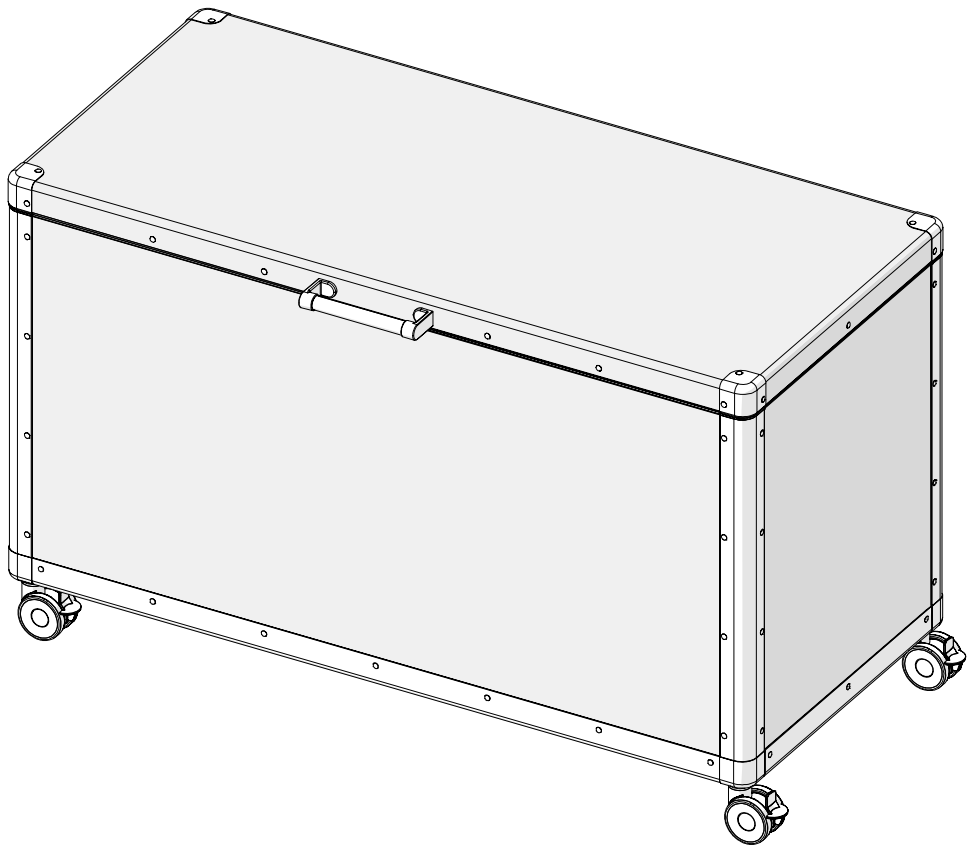

EN CARE & MAINTENANCE

FR ENTRETIEN ET MAINTENANCE

DE PFLEGE UND WARTUNG

NL VERZORGING EN ONDERHOUD



- EN Regularly clean the deck box to prevent permanent stains on the metal.
- FR Nettoyez régulièrement le coffre pour éviter les taches permanentes sur les parties métalliques.
- DE Deckbox regelmäßig reinigen, um Dauerflecken auf Metall zu vermeiden.
- NL Maak de opbergbox regelmatig schoon om blijvende vlekken op het metaal te voorkomen.



- EN Regularly check that all bolts and fittings are secure. Tighten if needed.
- FR Vérifiez régulièrement que tous les boulons et fixations sont bien serrés. Resserrez-les si nécessaire.
- DE Alle Schrauben und Befestigungen regelmäßig prüfen und ggf. nachziehen.
- NL Controleer regelmatig of alle bouten en fittingen goed vastzitten. Draai ze indien nodig vast.



- EN Use only manufacturer-approved replacement parts.
- FR Utilisez exclusivement des pièces de rechange approuvées par le fabricant.
- DE Nur vom Hersteller zugelassene Ersatzteile verwenden.
- NL Gebruik alleen door de fabrikant goedgekeurde vervangende onderdelen.



- EN Use water/mild soap and air dry/wipe with a soft clean cloth to clean the deck box.
- FR Pour nettoyer la boîte, utilisez de l'eau et du savon doux. Séchez-le ensuite à l'air libre ou en le tamponnant avec un chiffon doux et propre.
- DE Deckbox mit Wasser/milder Seife reinigen und an der Luft trocknen lassen/mit einem weichen, sauberen Tuch abwischen.
- NL Gebruik water/zachte zeep en laat de opbergbox aan de lucht drogen/veeg hem schoon met een zachte, schone doek.



- EN Do not use any bleach, ammonia, acidic, alkaline or other caustic cleaners.
- FR N'utilisez pas d'eau de Javel, d'ammoniaque, de produits acides, alcalins ou tout autre nettoyeur corrosif.
- DE Keine Bleichmittel, Ammoniak, säurehaltigen, alkalischen oder anderen ätzenden Reiniger verwenden.
- NL Gebruik geen bleekmiddel, ammoniak, zure, alkalische of andere bijtende reinigingsmiddelen.

EN WARRANTY & COMPLAINTS PROCEDURE

FR GARANTIE ET PROCÉDURE DE RÉCLAMATION

DE GARANTIE- UND REKLAMATIONSVERFAHREN

NL GARANTIE- EN KLACHTENPROCEDURE

LIMITED WARRANTY / GARANTIE LIMITÉE / BEGRENZTE GARANTIE / BEPERKTE GARANTIE

EN For terms and conditions of our limited warranty, please visit [MIRADOROUTDOOR.COM](https://www.miradoroutdoor.com) or contact your local Mirador sales representative.

FR Pour connaître les conditions de notre garantie limitée, veuillez vous rendre sur le site [MIRADOROUTDOOR.COM](https://www.miradoroutdoor.com) ou contactez votre représentant commercial Mirador local.

DE Für die Bedingungen unserer begrenzten Garantie besuchen Sie bitte [MIRADOROUTDOOR.COM](https://www.miradoroutdoor.com) oder kontaktieren Sie Ihren örtlichen Mirador-Vertriebsmitarbeiter.

NL Voor de voorwaarden van onze beperkte garantie, bezoek [MIRADOROUTDOOR.COM](https://www.miradoroutdoor.com) of neem contact op met uw lokale Mirador-vertegenwoordiger.

Contact / Contact / Kontakt / Contactgegevens

 **Online / En ligne / Online / Online**
[miradoroutdoor.com](https://www.miradoroutdoor.com)

Operation hours: Monday - Friday: 9:00 am - 6:00 pm, CET.
Heures d'ouverture: Du lundi au vendredi : de 9 h 00 à 18 h (CET).
Betriebszeiten: Montag - Freitag: 9:00 - 6:00 Uhr, CET.
Openingstijden: Maandag - vrijdag: 9:00 - 18:00 uur, CET.

 **E-mail / E-mail / E-Mail / E-mail**
customerservice@miradoroutdoor.com

Operation hours: We are available 24 hours a day. Please allow up to 24 hours for a response.
Heures d'ouverture: Nous sommes disponibles 24 heures sur 24. Veuillez compter jusqu'à 24 heures pour une réponse.
Betriebszeiten: Wir sind 24 Stunden am Tag erreichbar. Bitte warten Sie bis zu 24 Stunden auf eine Antwort.
Openingstijden: Wij zijn 24 uur per dag bereikbaar. U kunt tot 24 uur wachten op een reactie.

1300

more to
enjoy

FOLLOW US ON
WWW.MIRADOROUTDOOR.COM

 @miradoroutdoor  @MiradorOutdoor
 @miradoroutdoor  @miradoroutdoor

