

Montageanleitung Installation instructions Instructions de montage Montagehandleiding

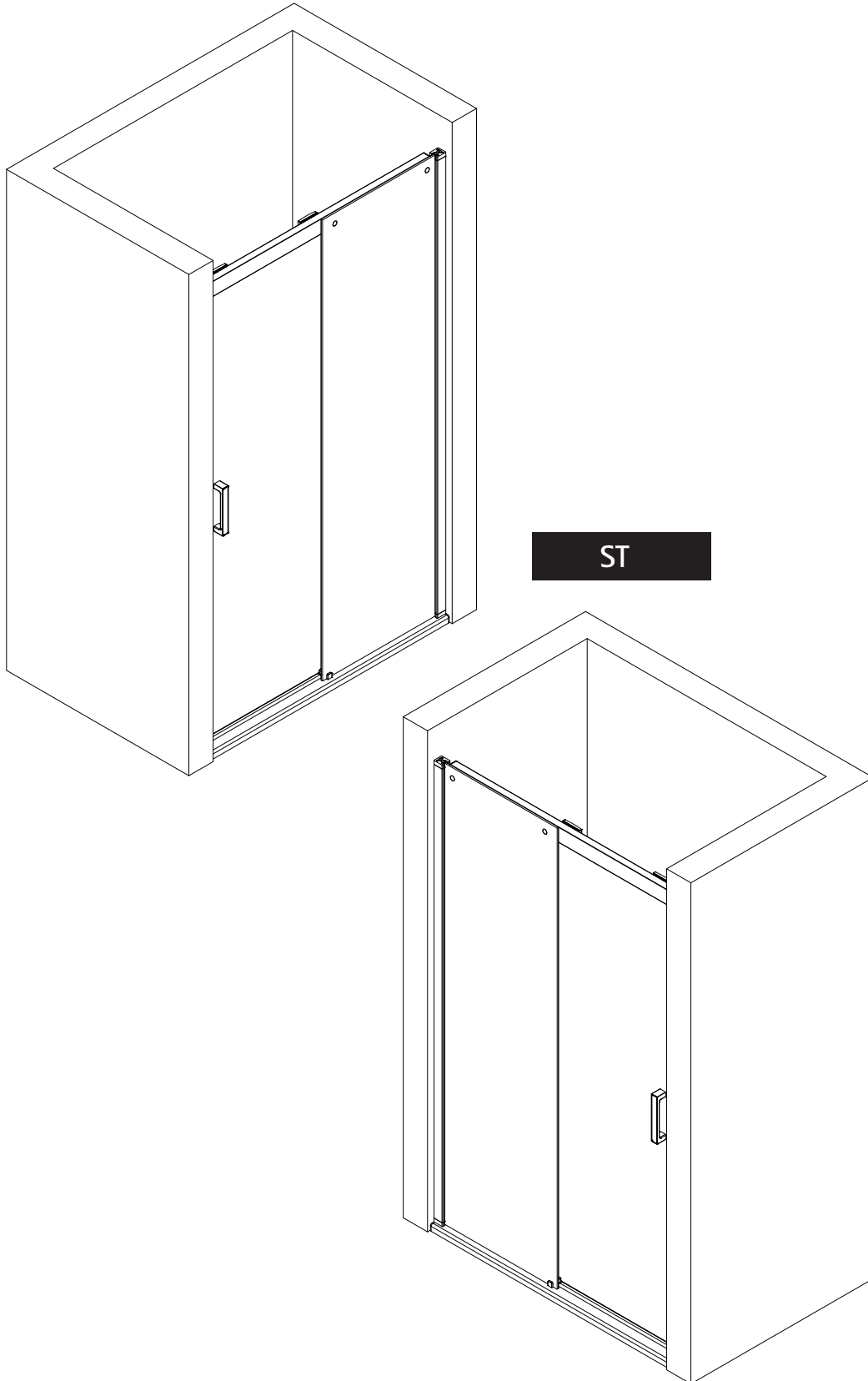

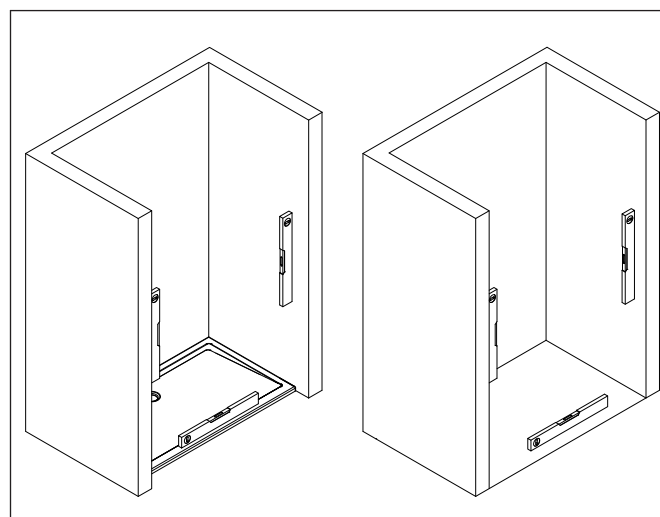

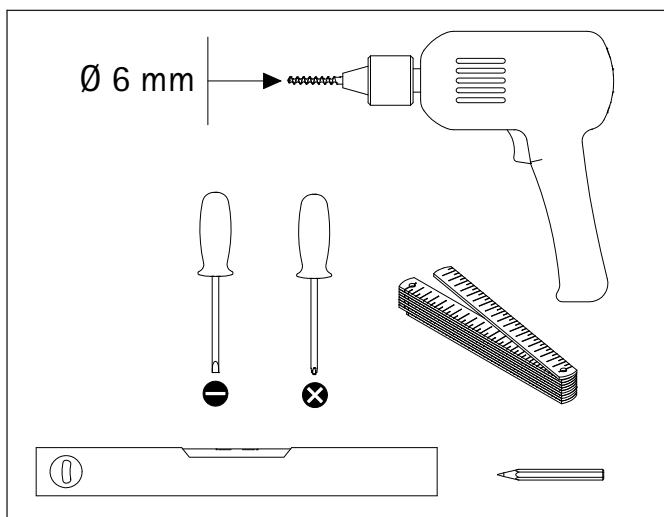
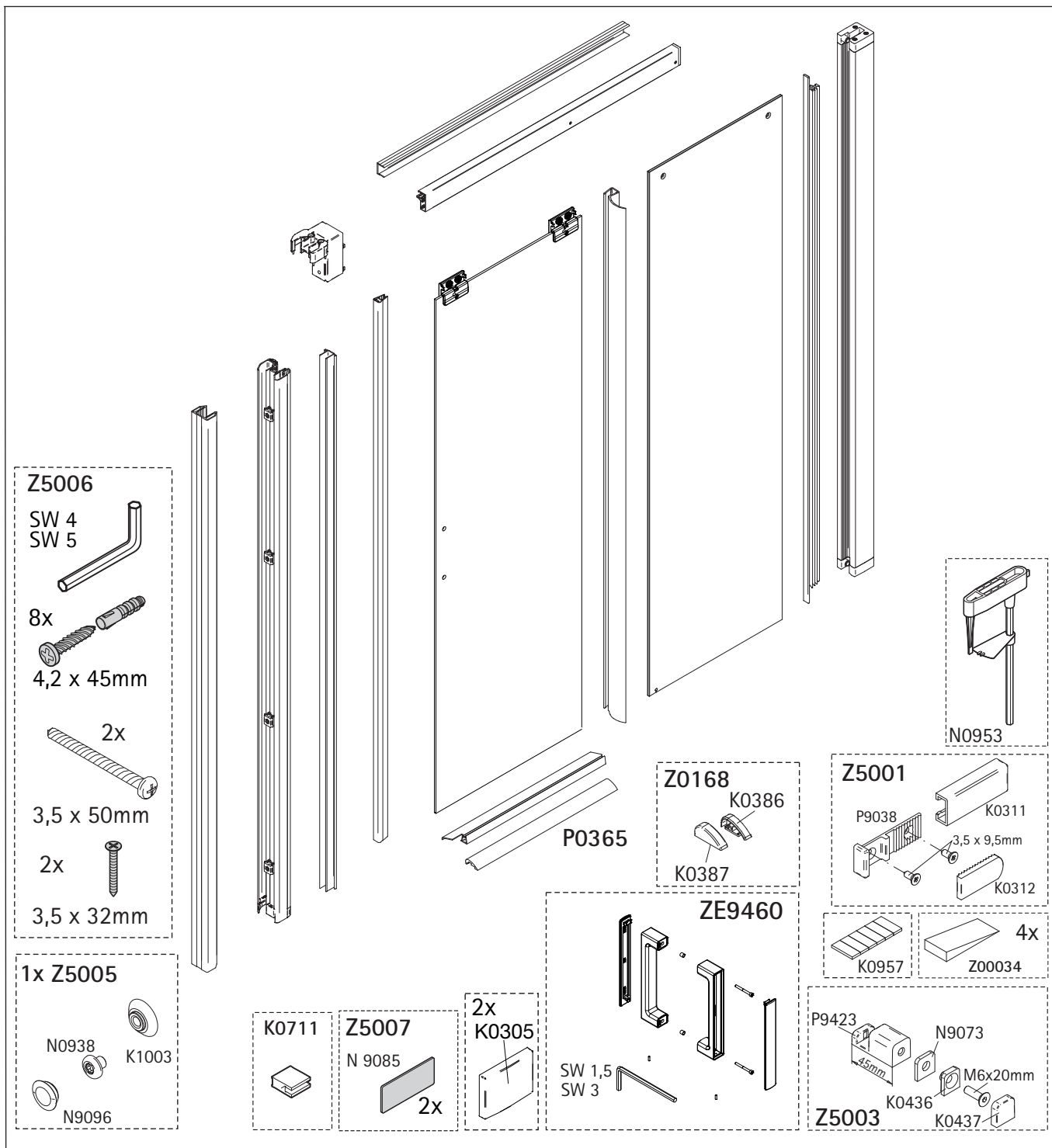
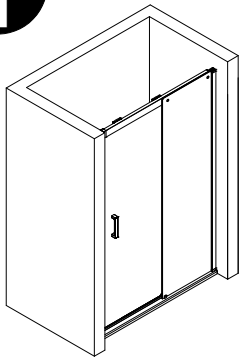

Anschlag rechts
fixed panel right
fixation droite
montagezide rechts

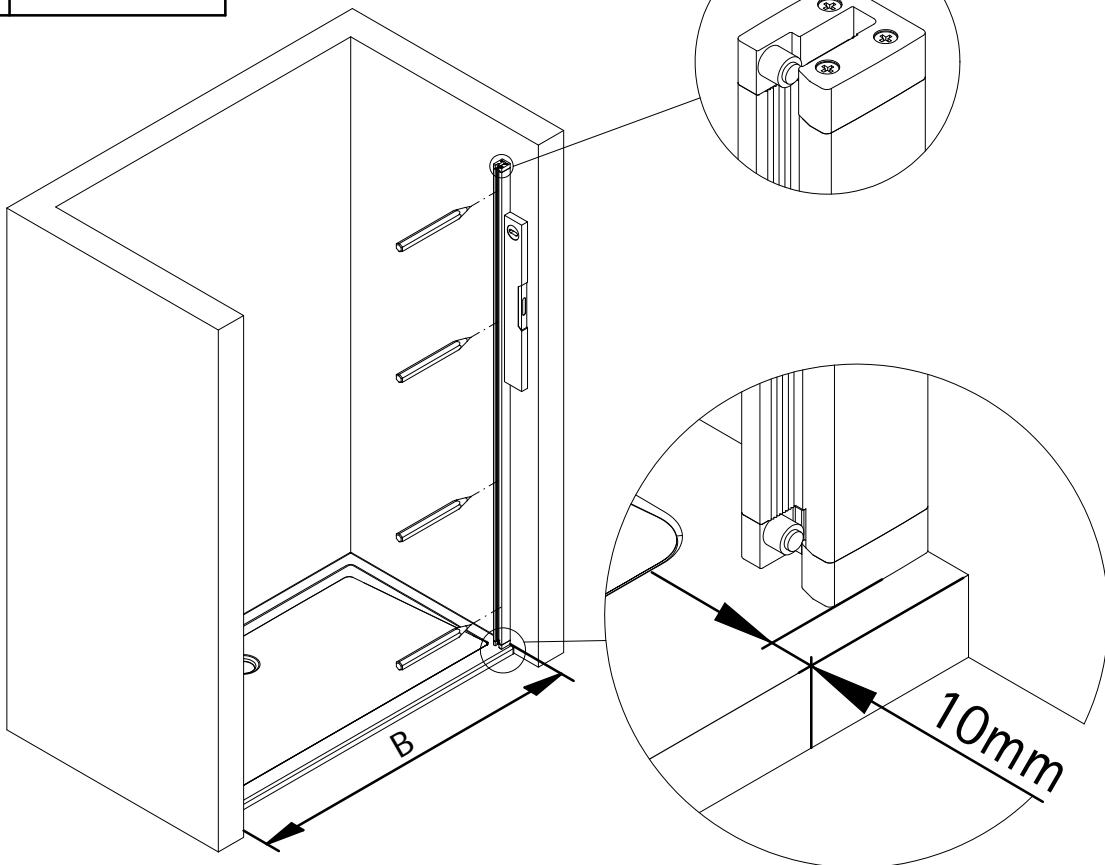
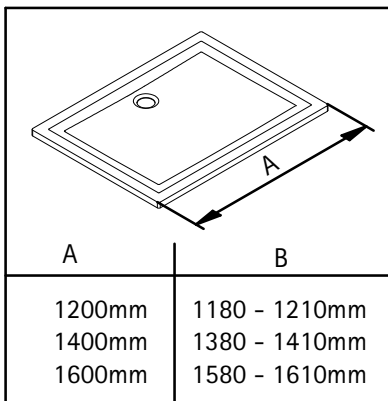
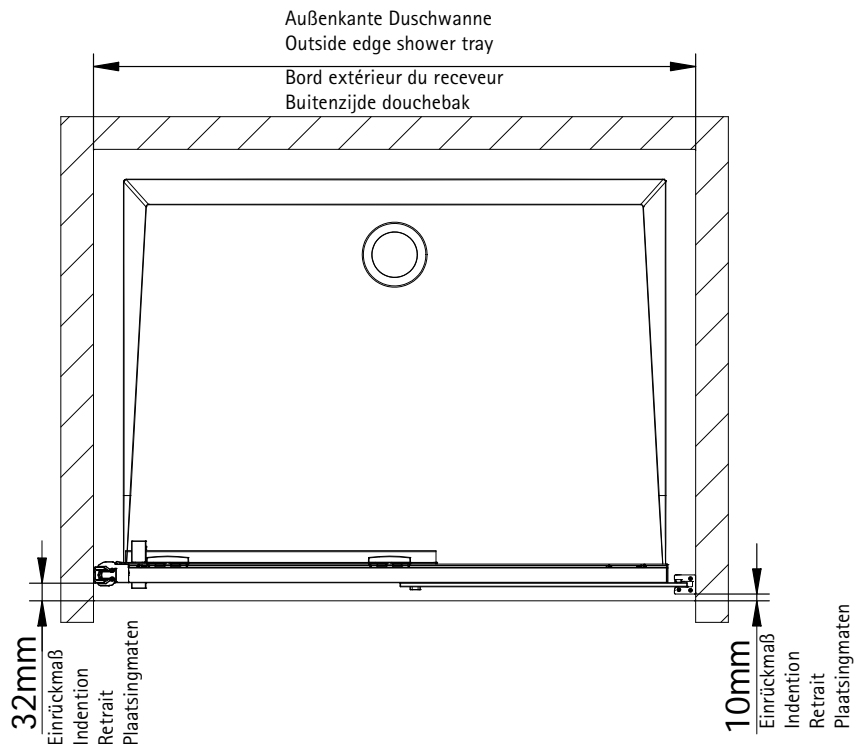

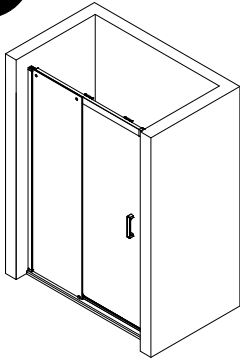

Anschlag links
fixed panel left
fixation gauche
montagezijde links

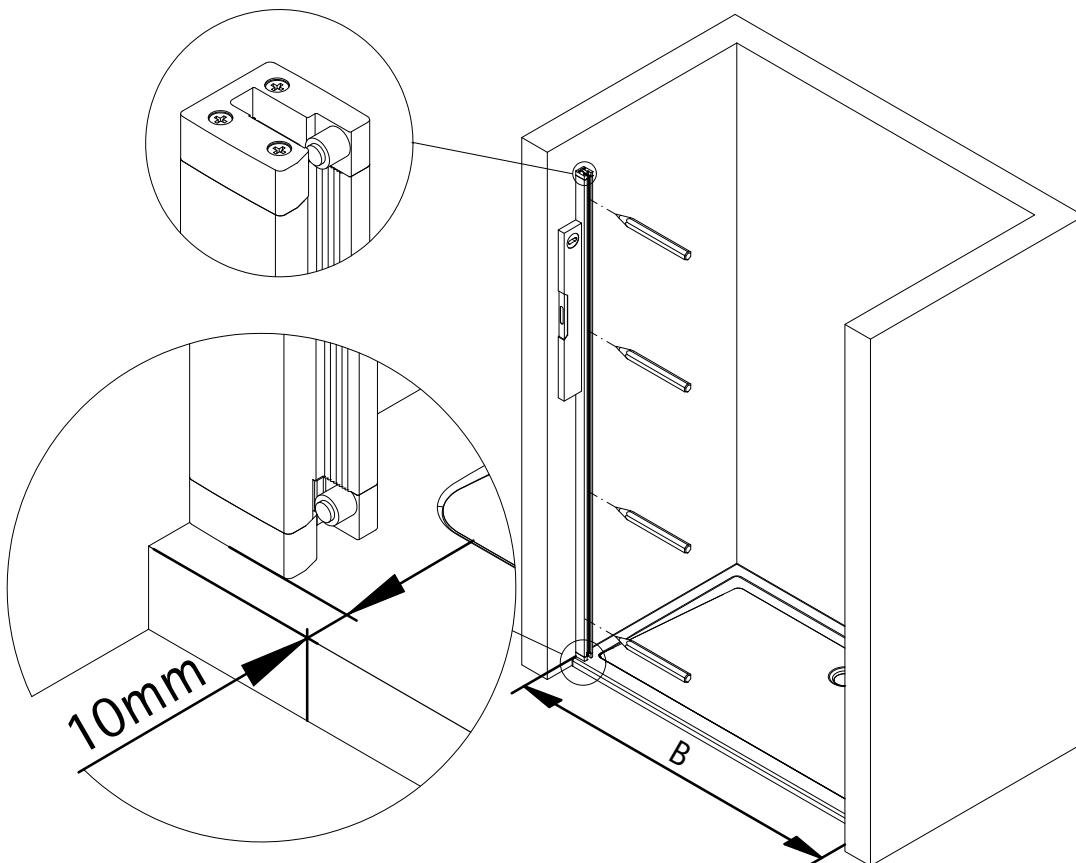
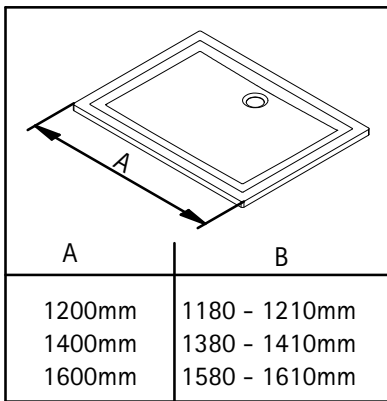
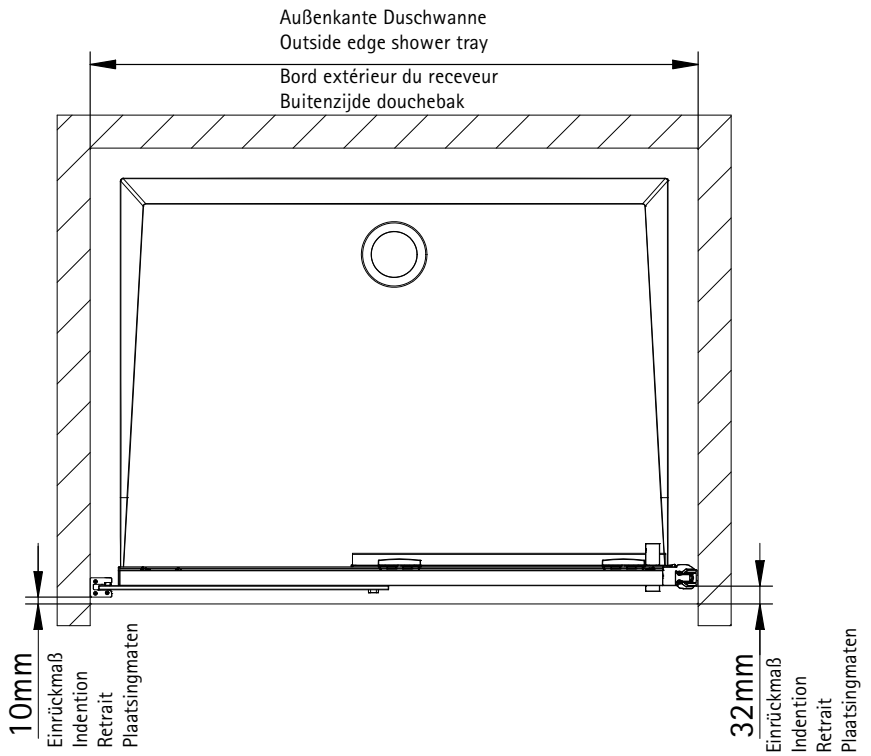

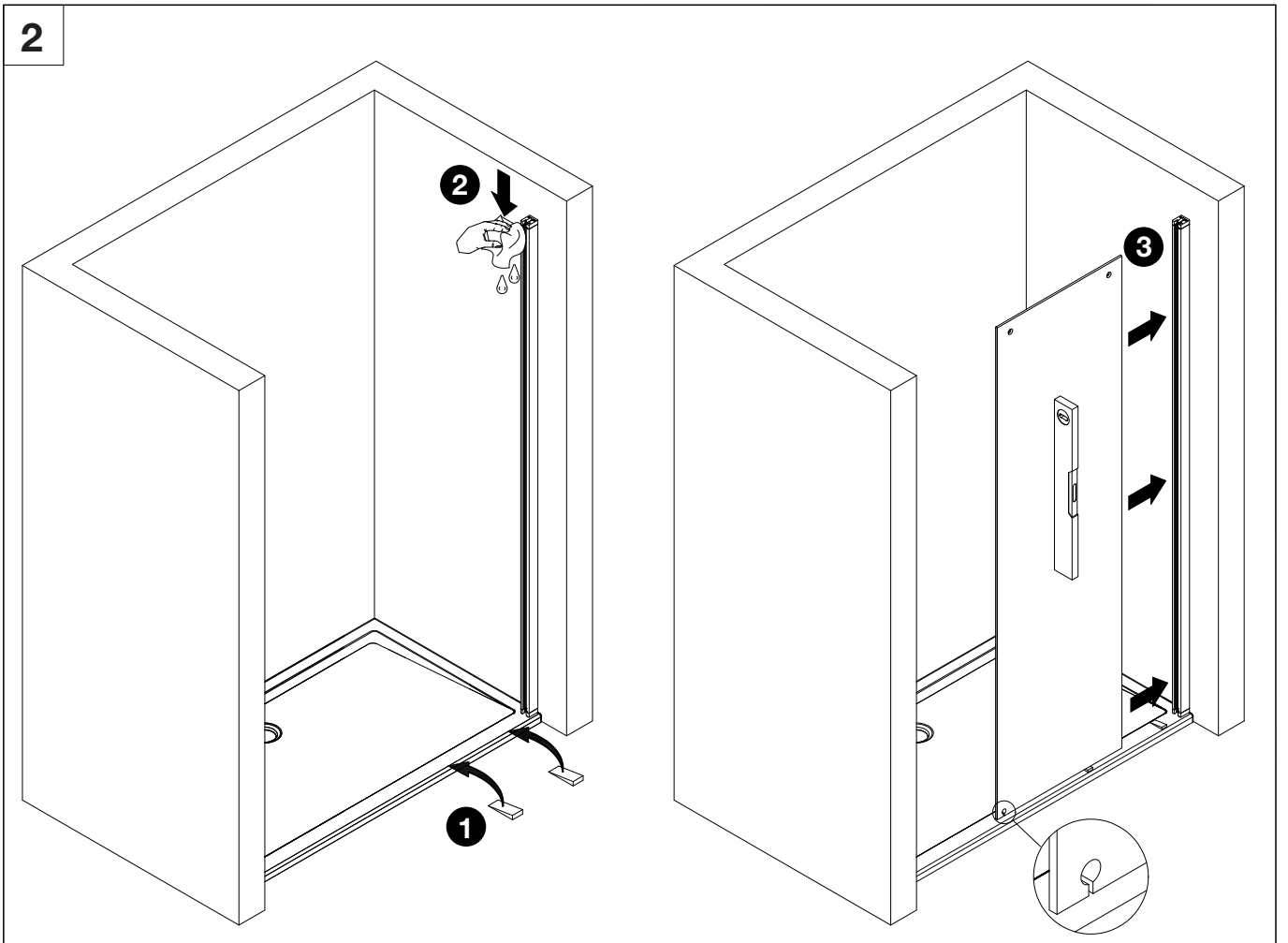
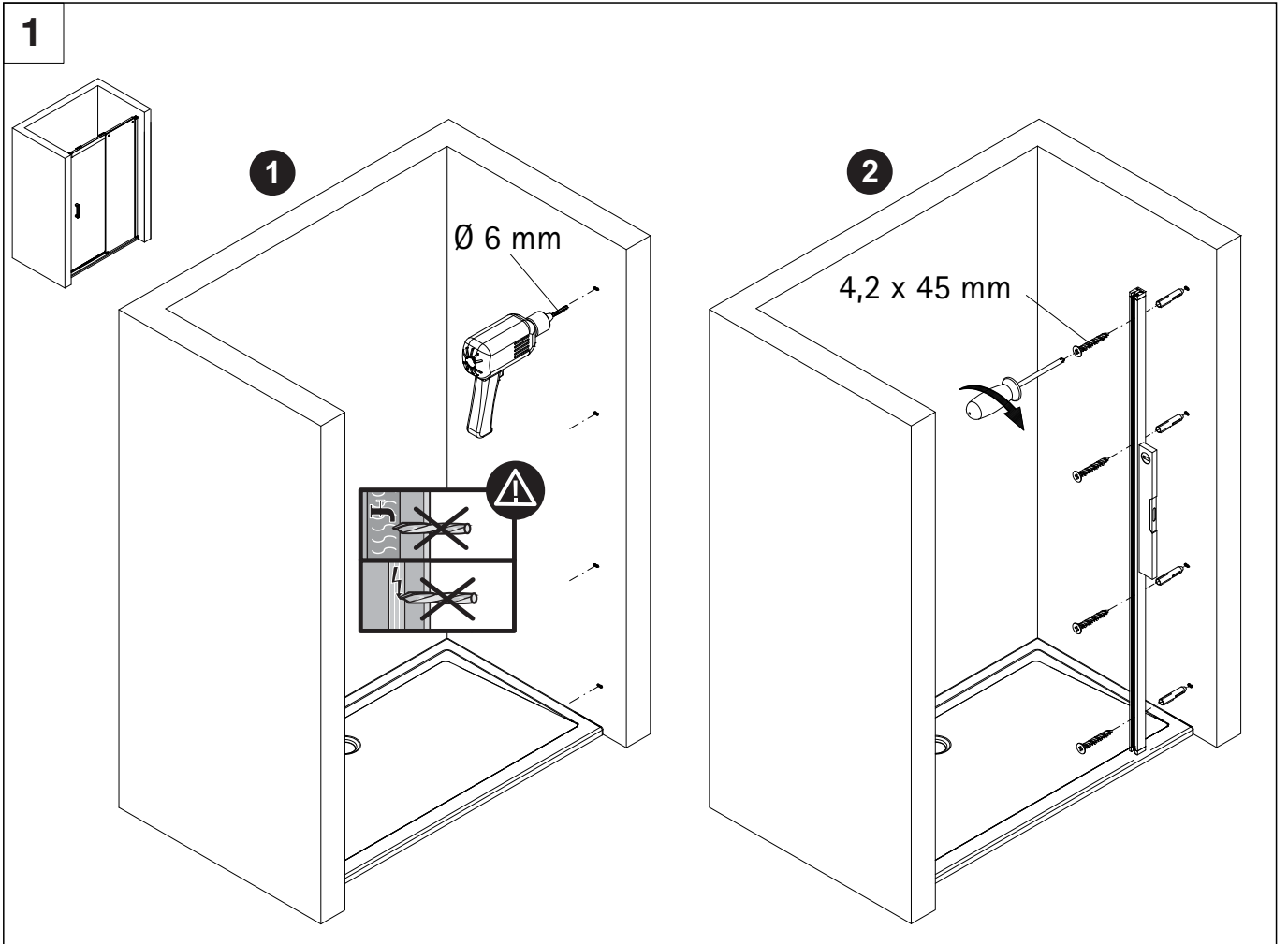

3

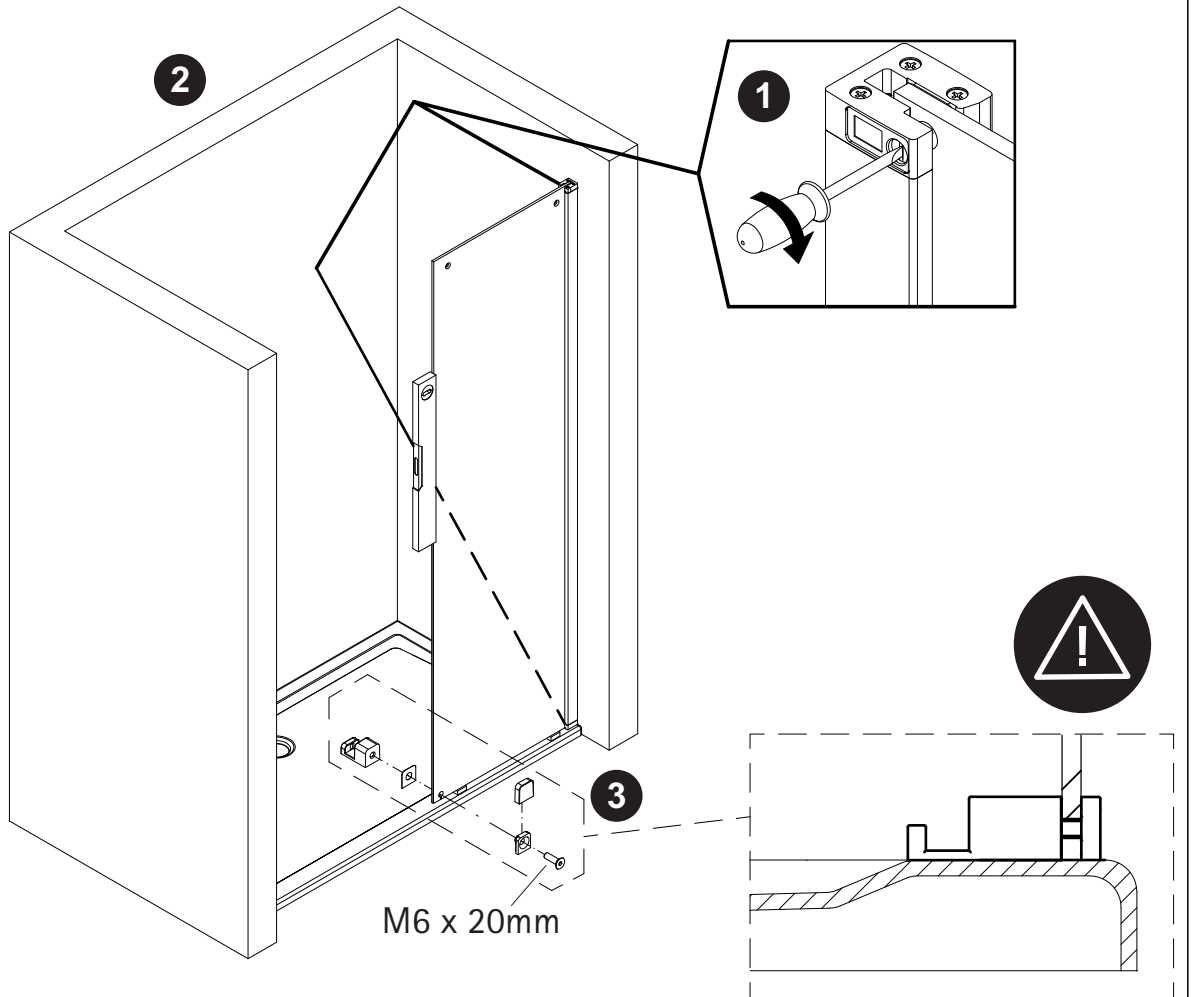

4

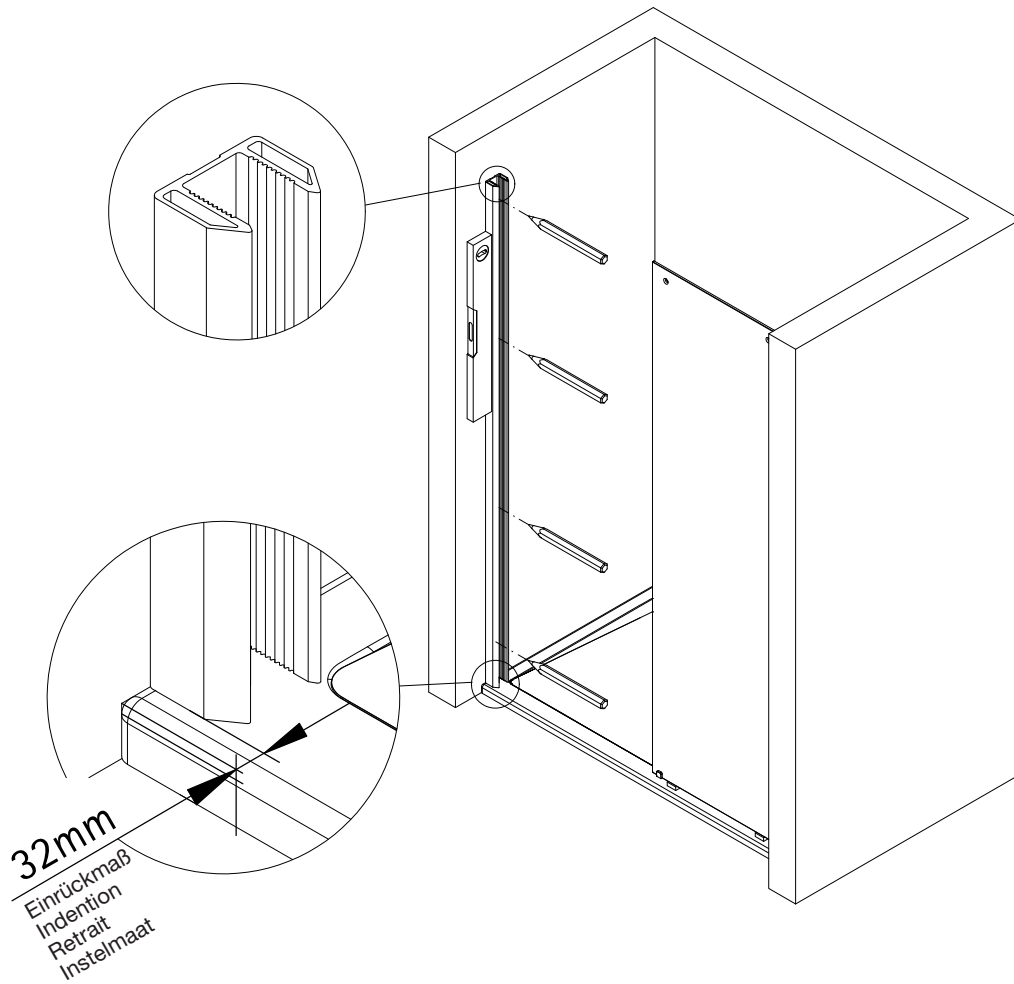

5

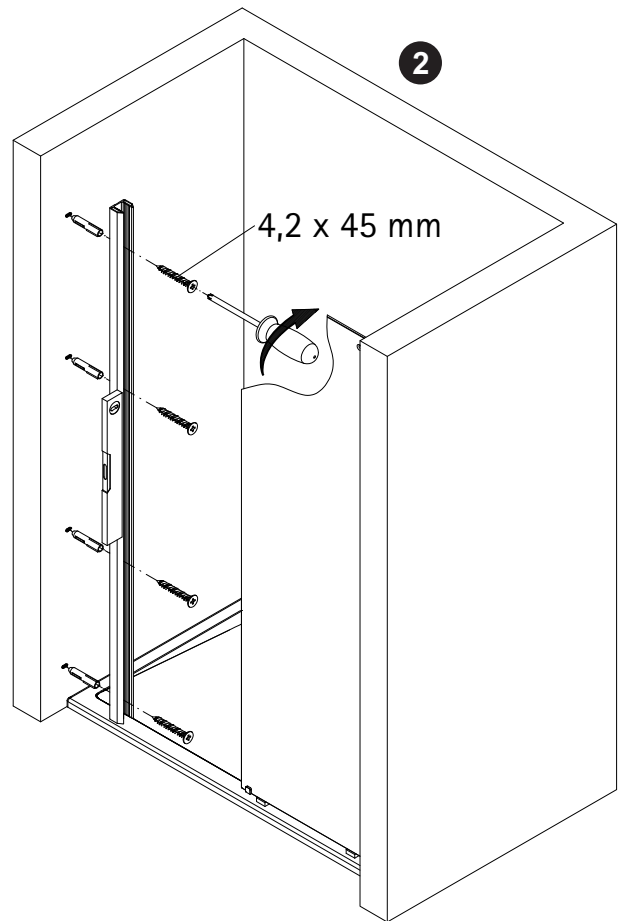
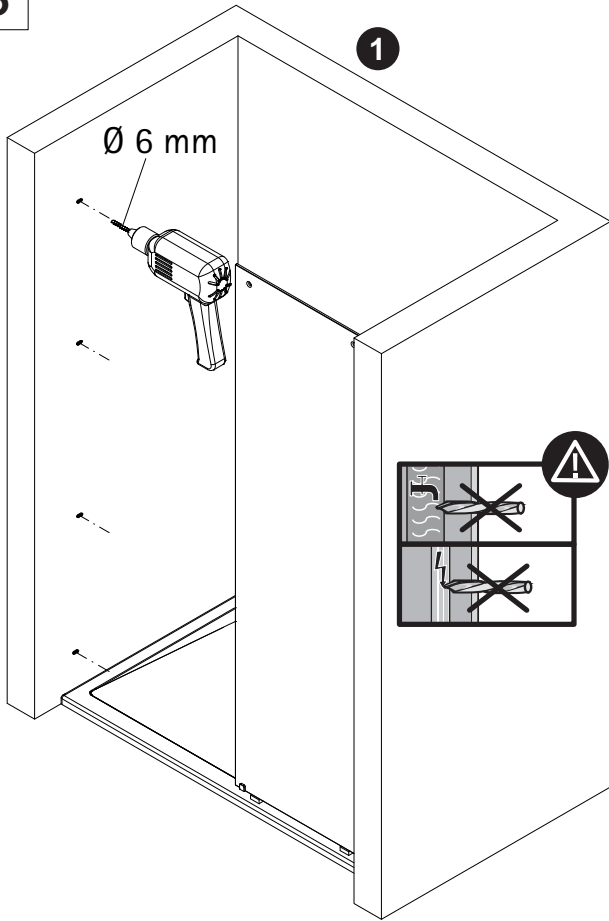

6

Vormontiert
pre-assembled
pré-assemblé
voorgemonteerd

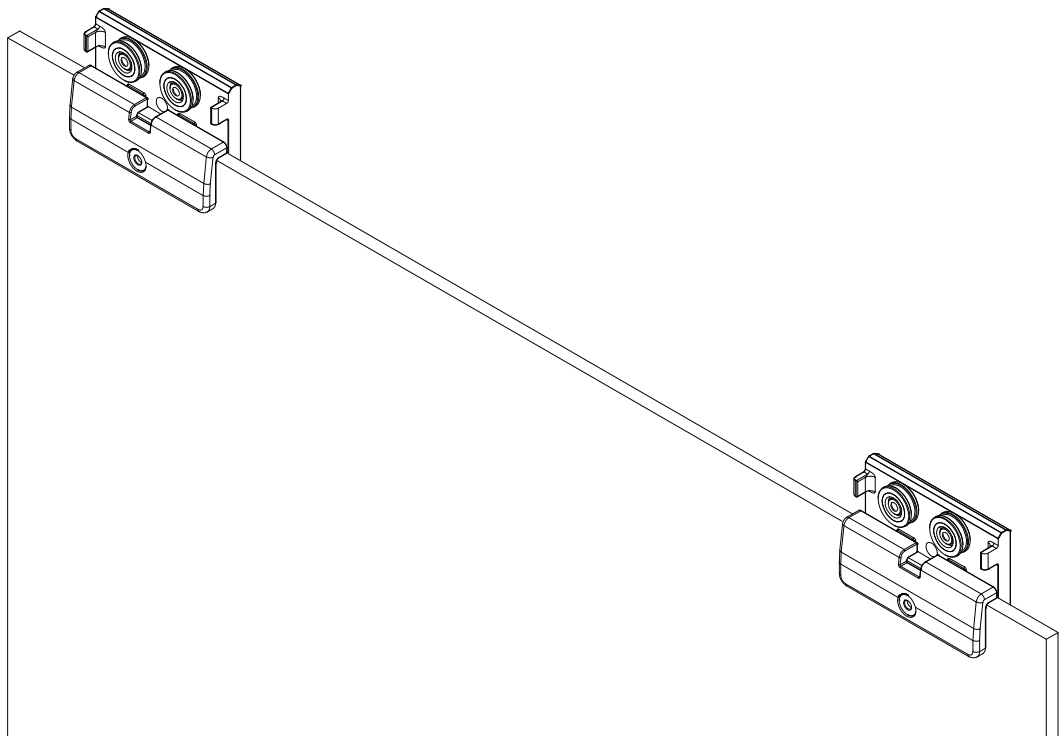

7

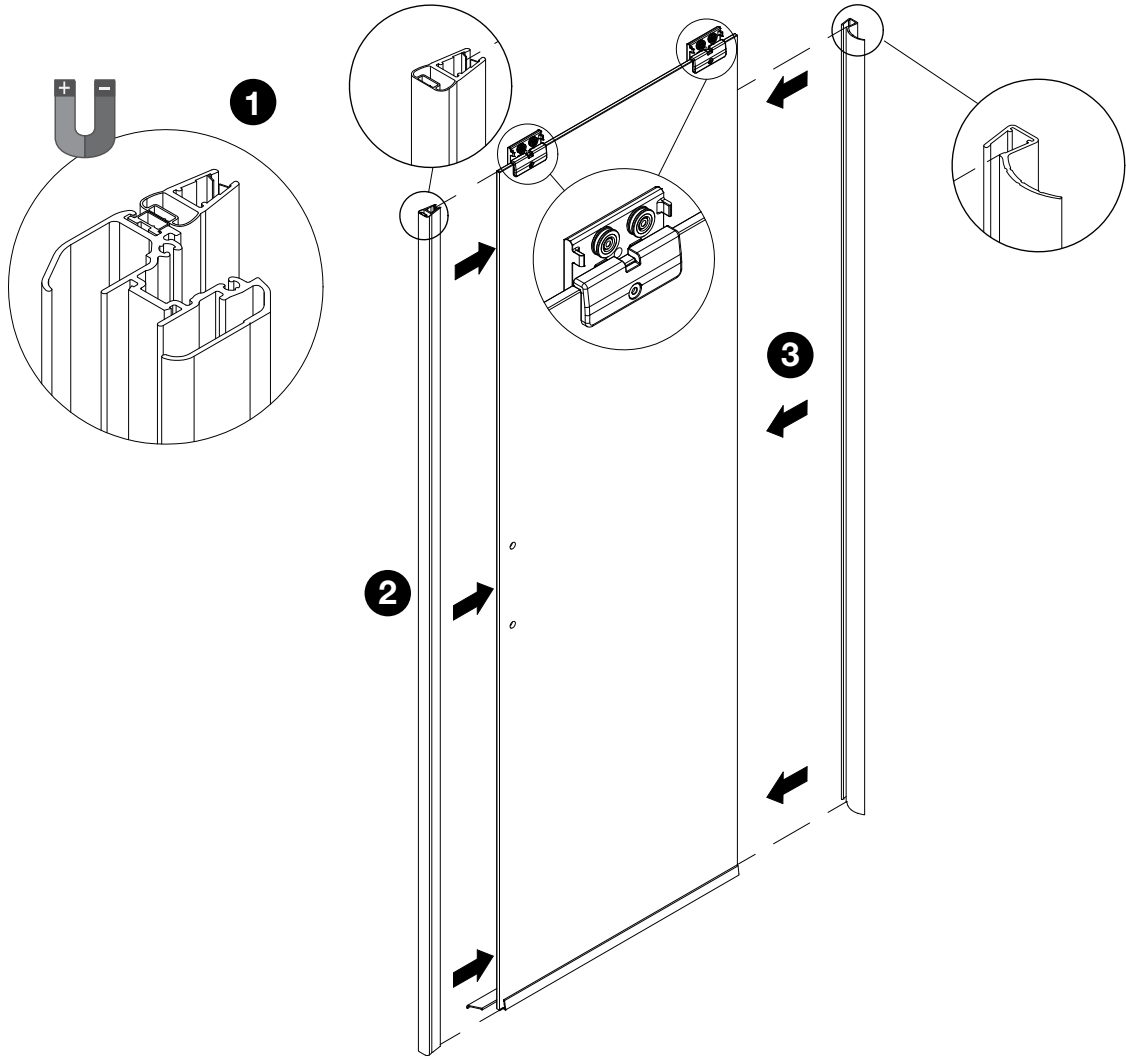

8

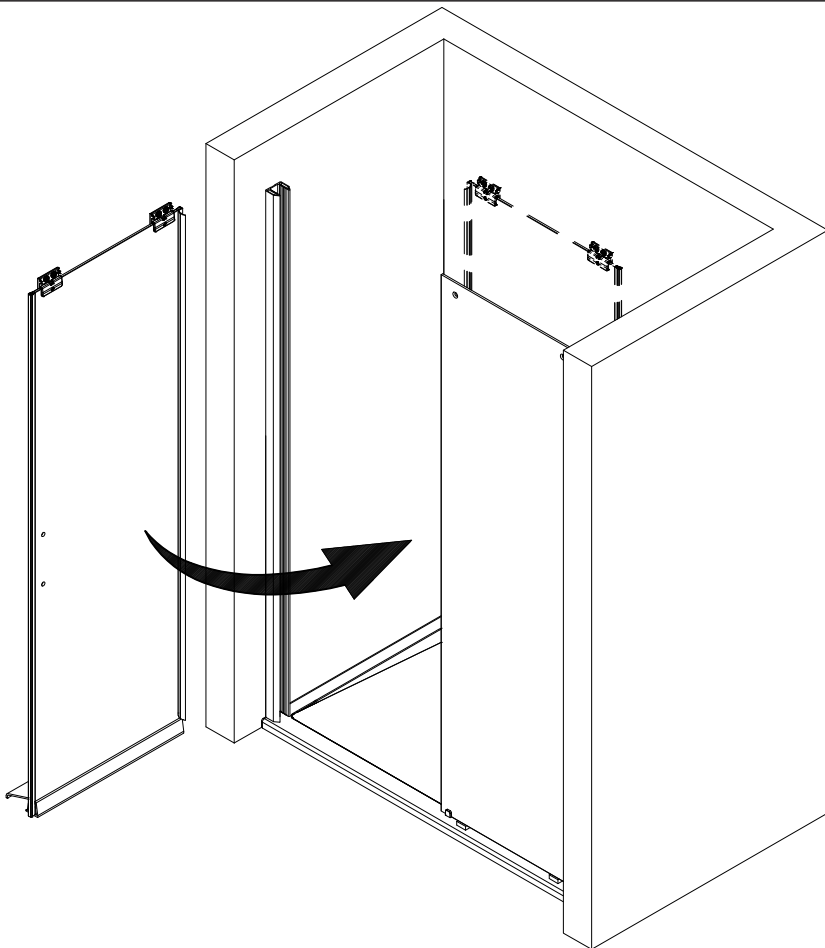

9

Anschlag rechts
fixed panel right
fixation droite
montagezijde rechts

Anschlag links
fixed panel left
fixation gauche
montagezijde links

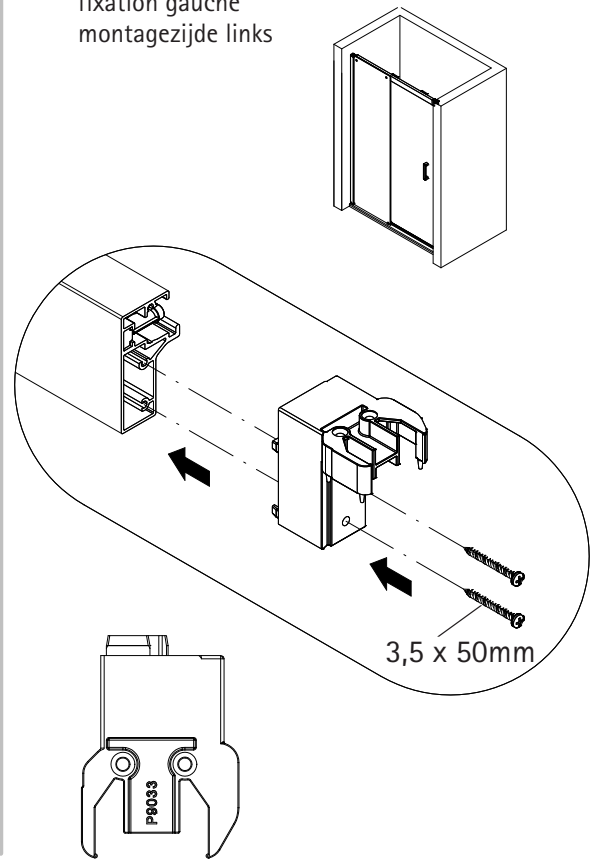
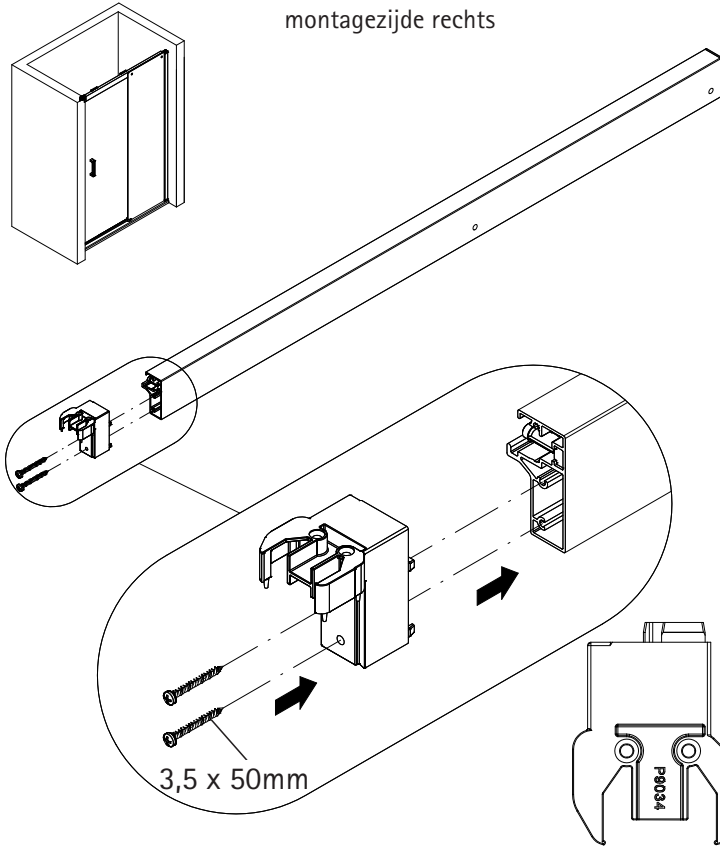

10

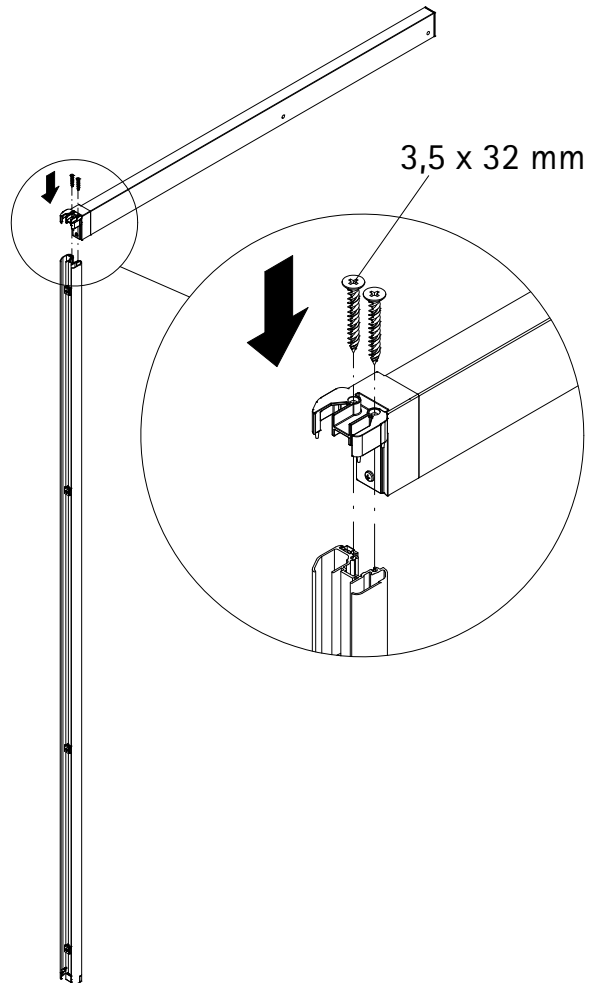

11

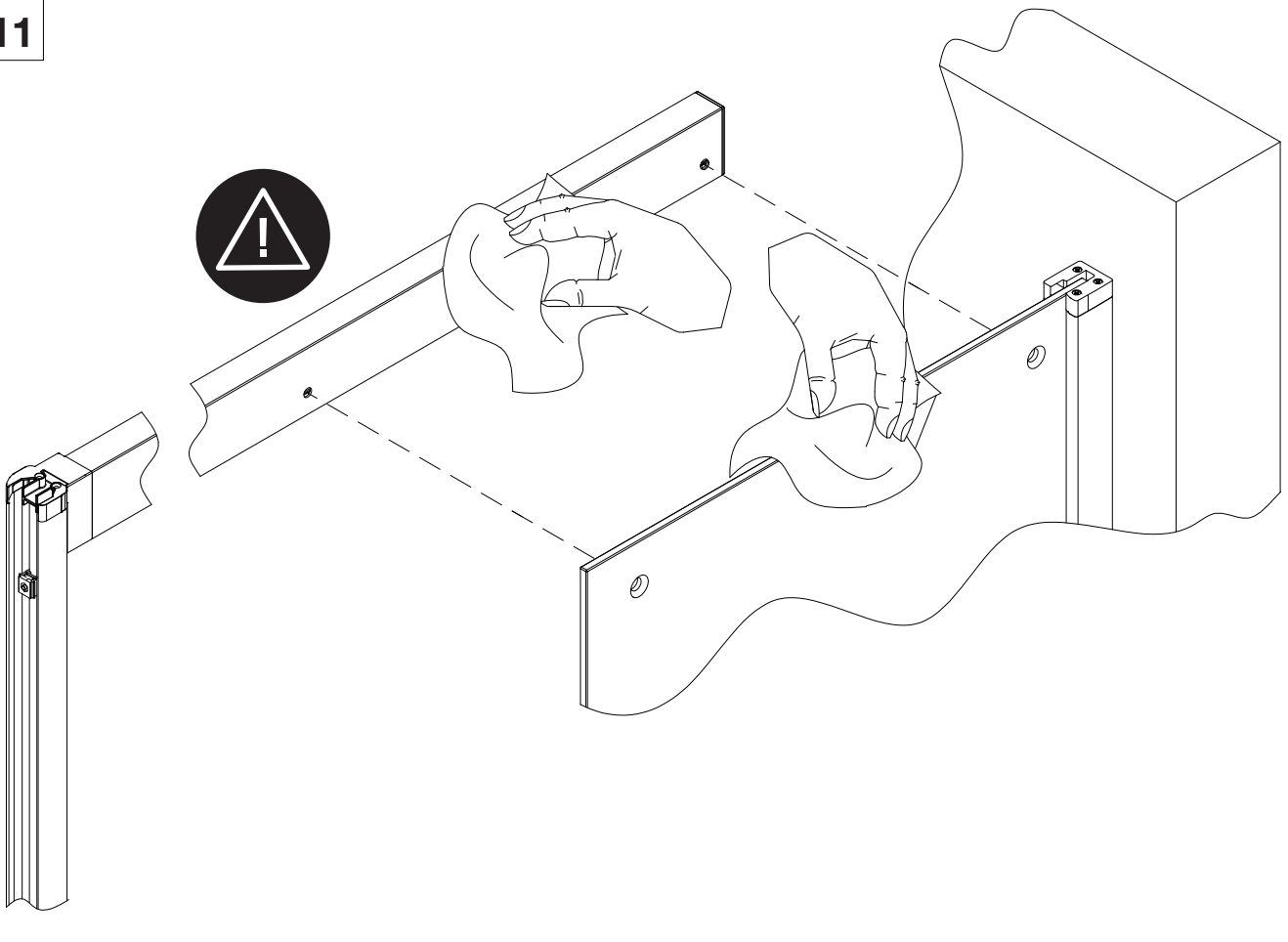

12

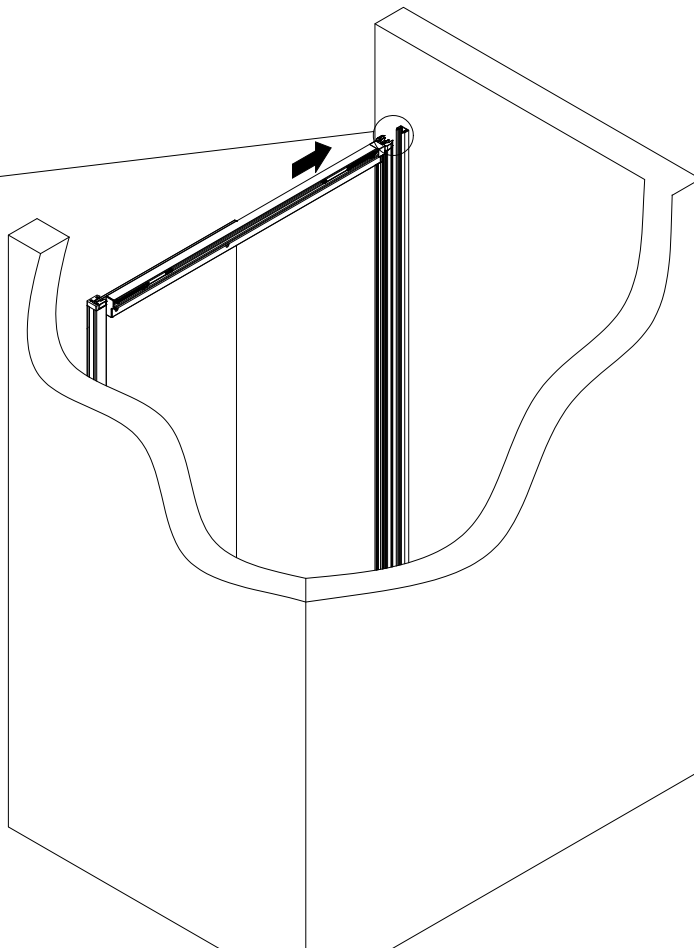
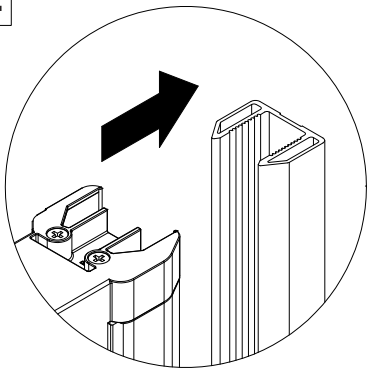

13

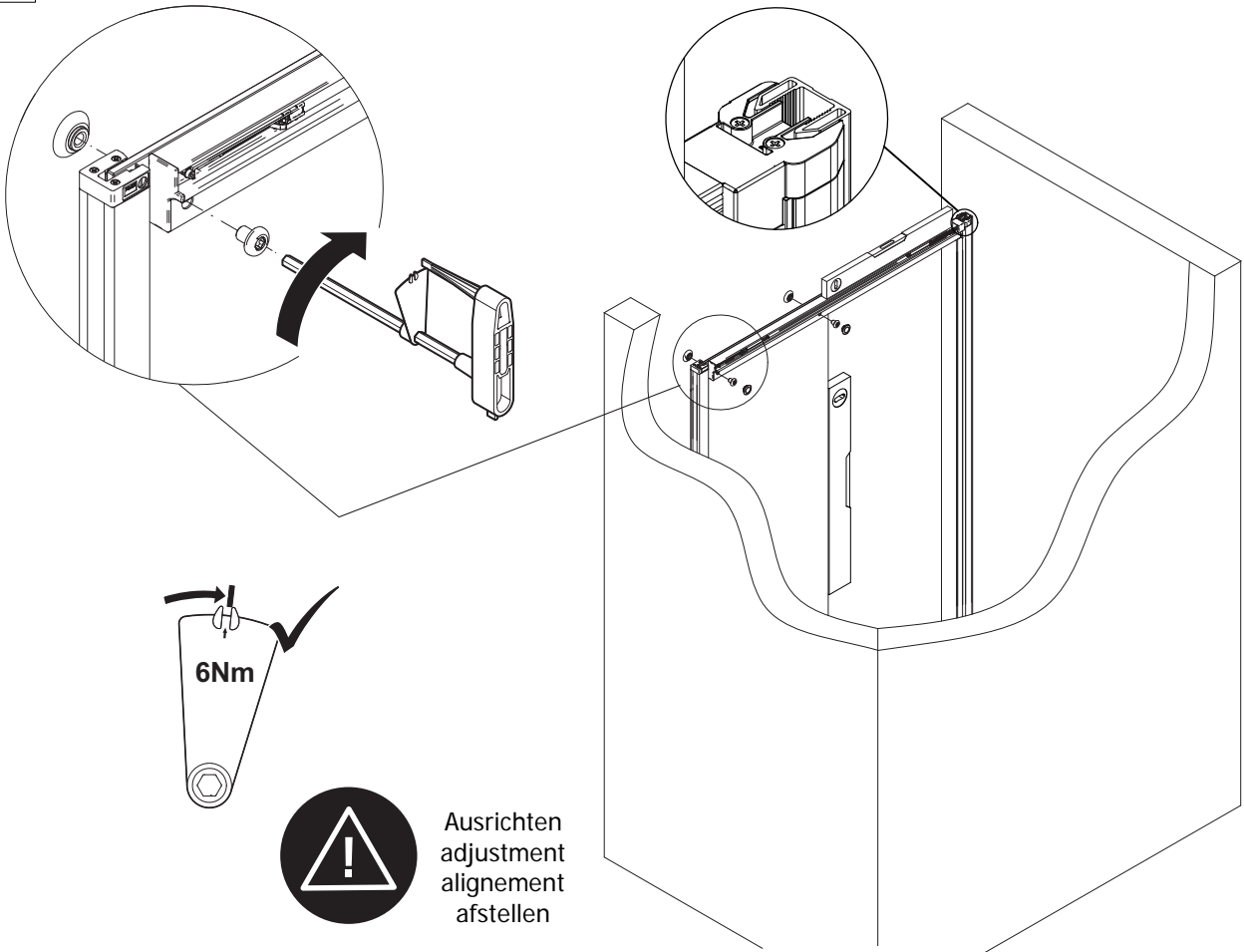

14

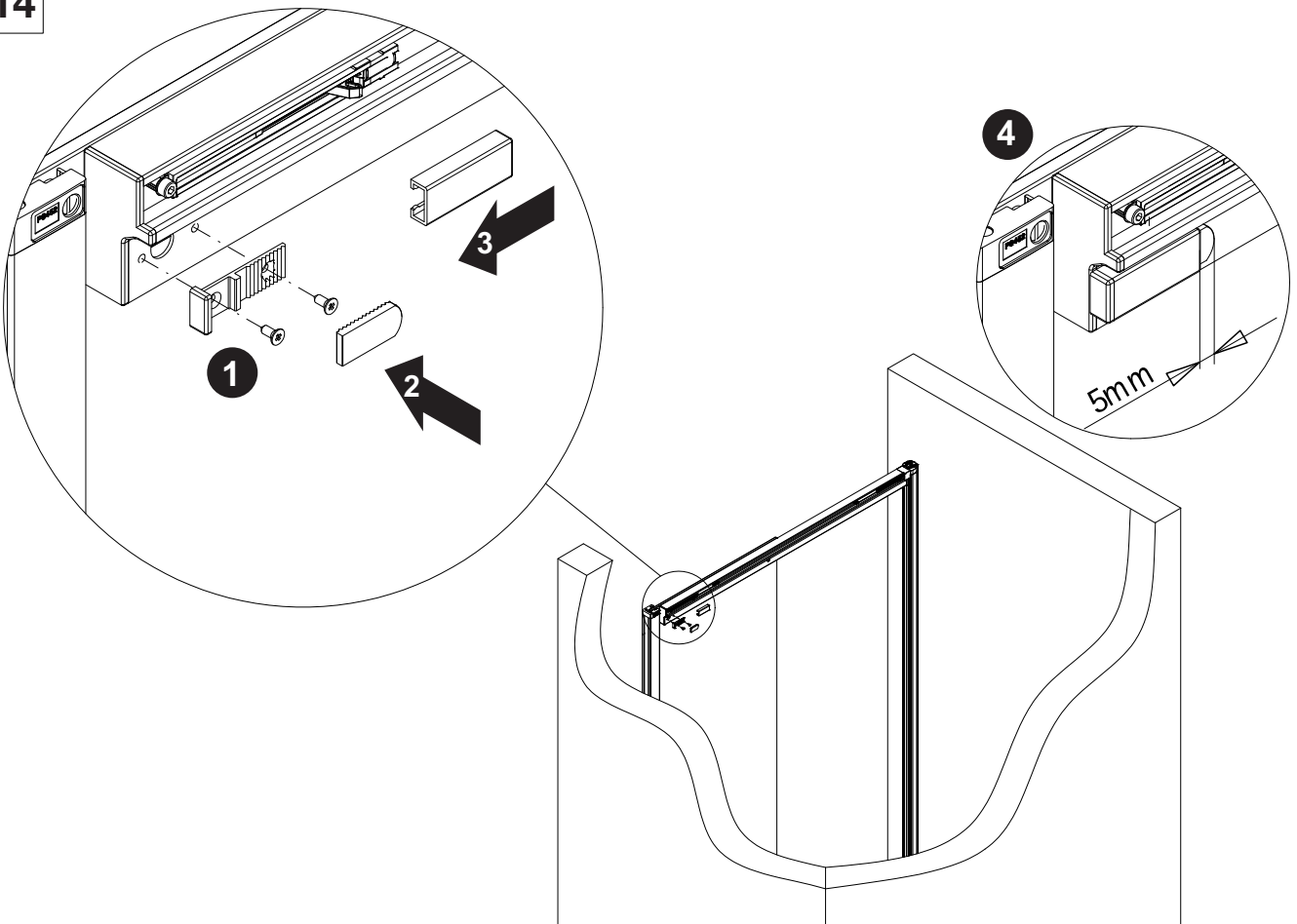

15

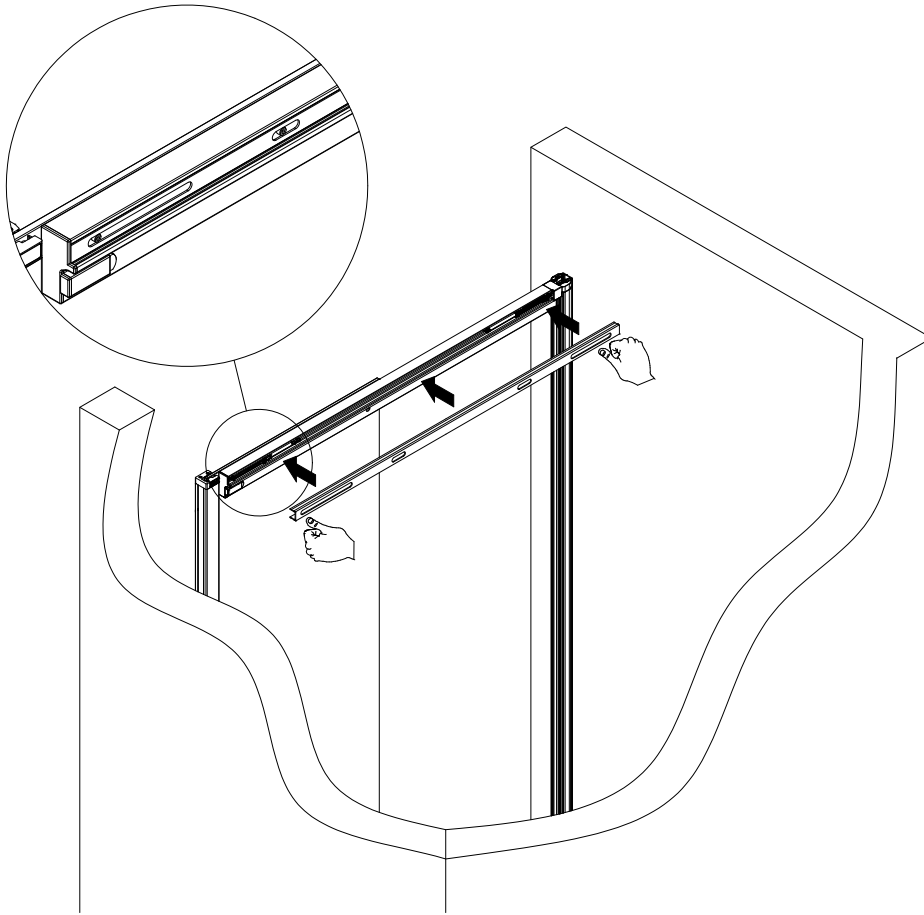

16

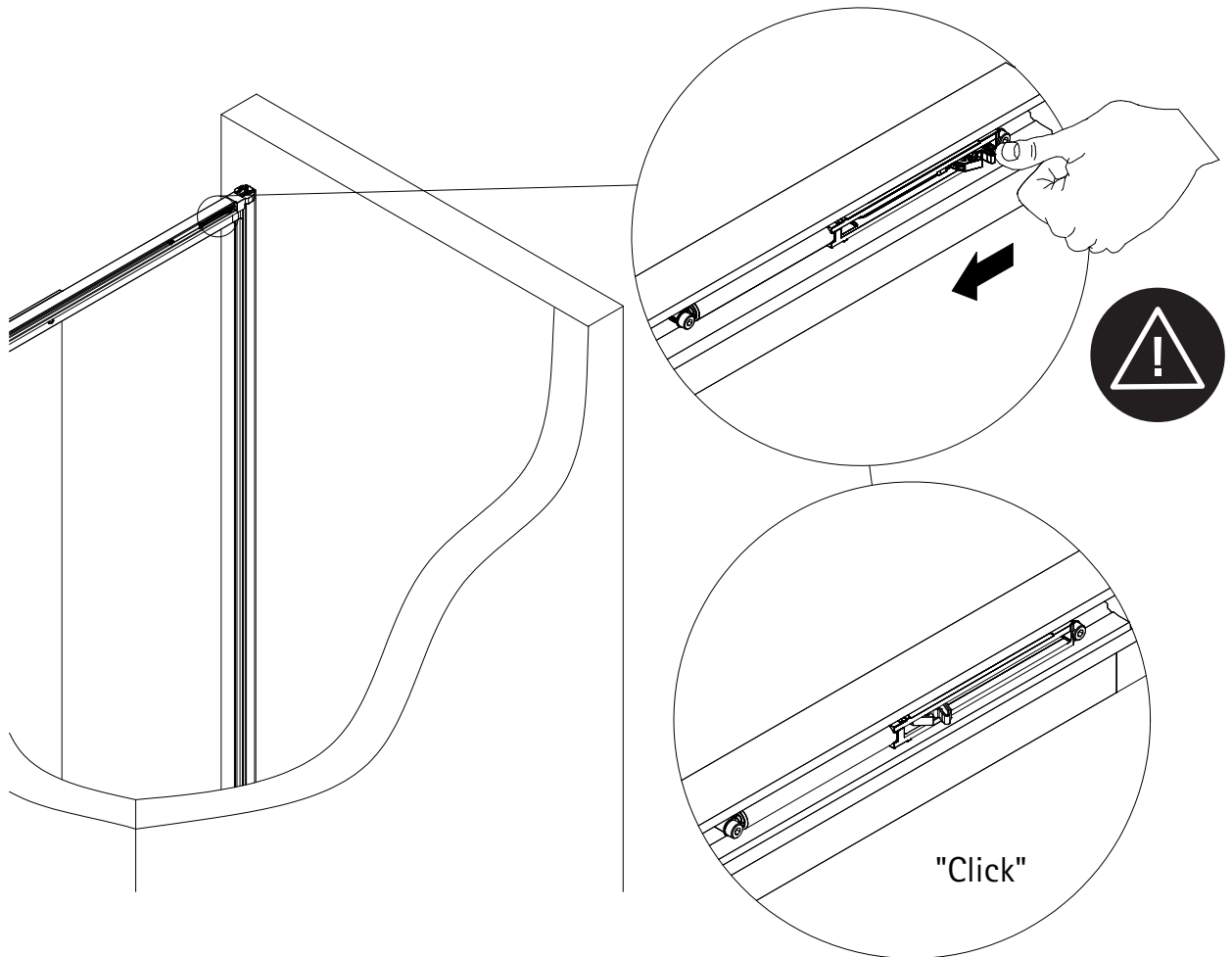

17

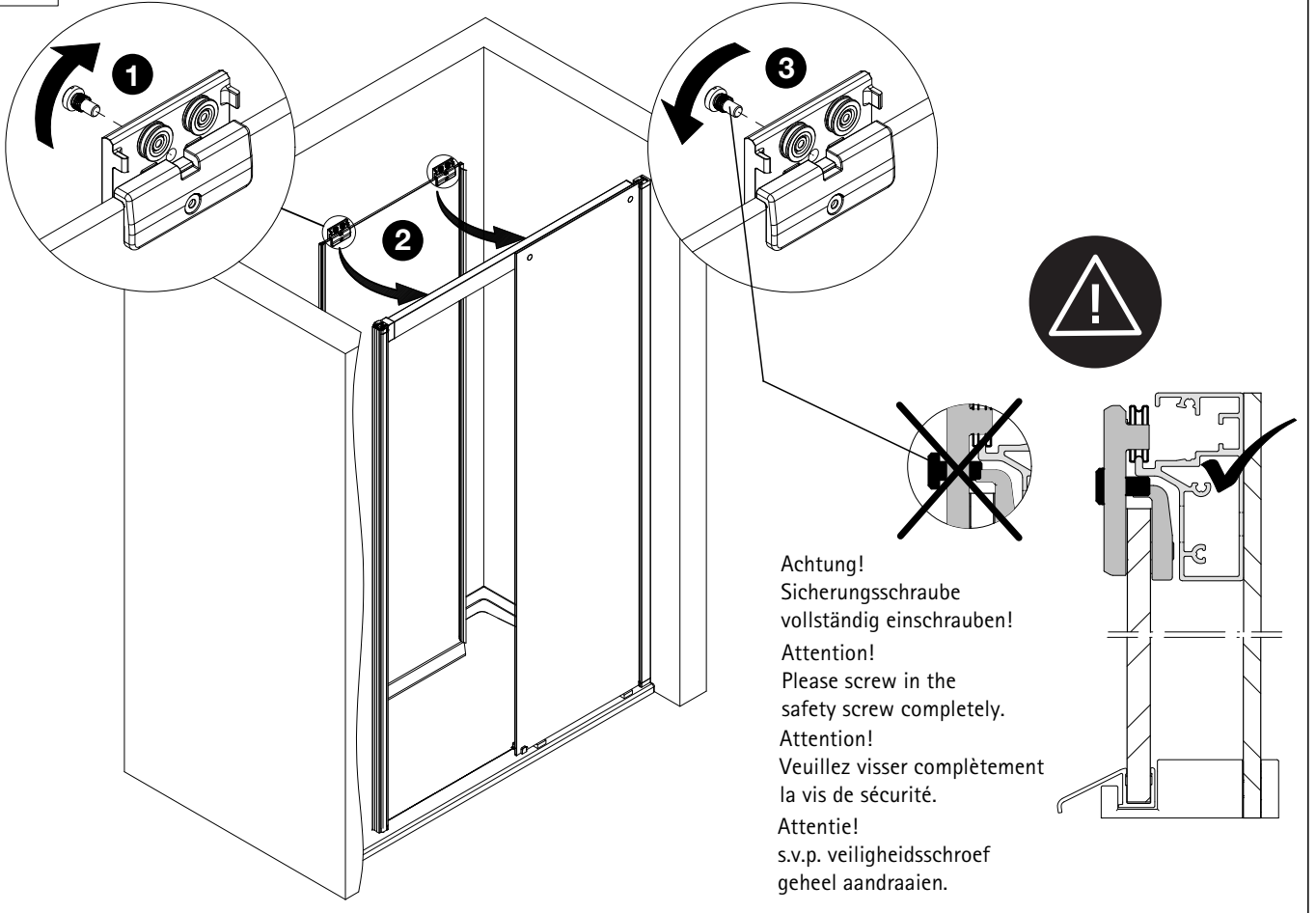

18

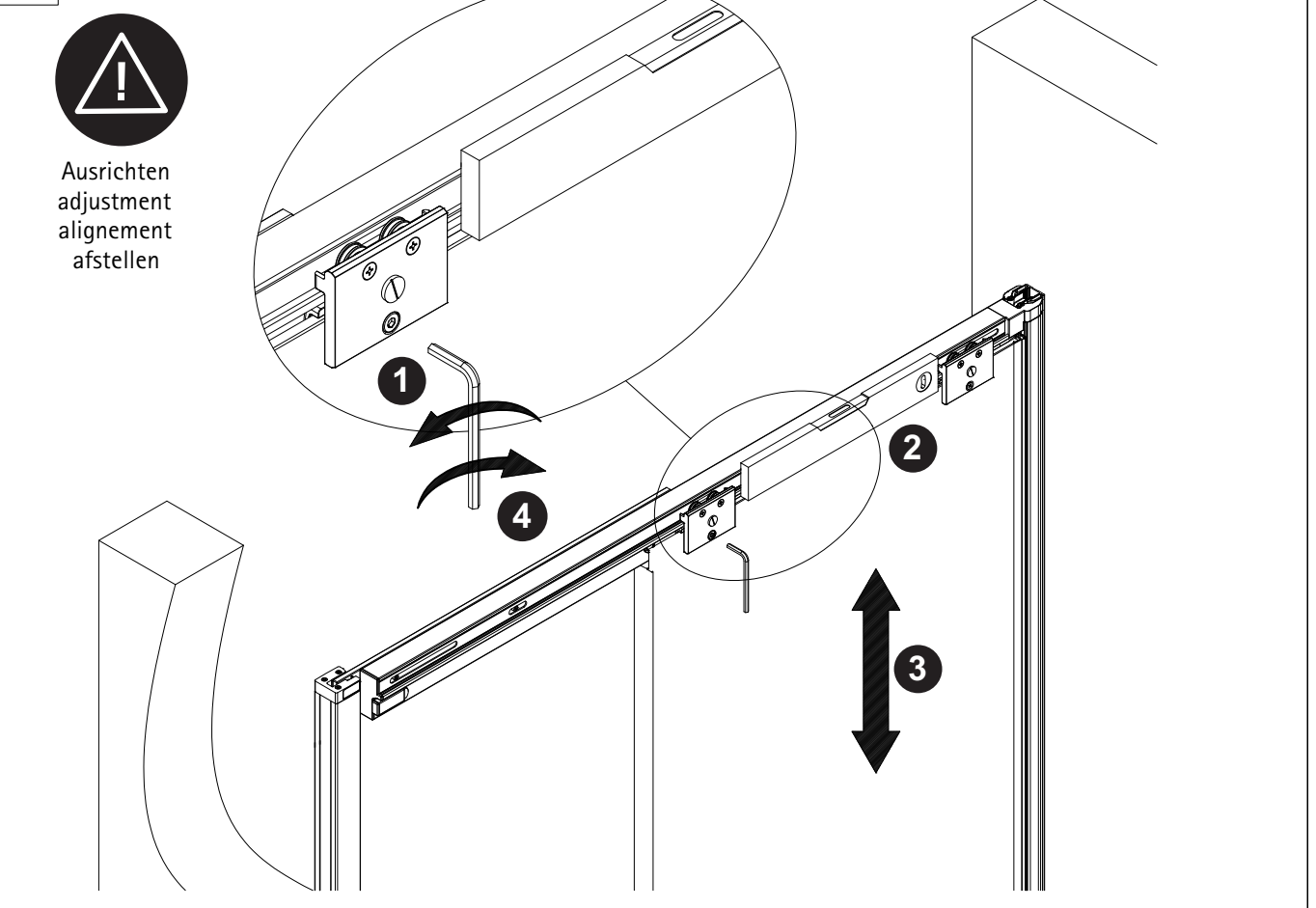

19

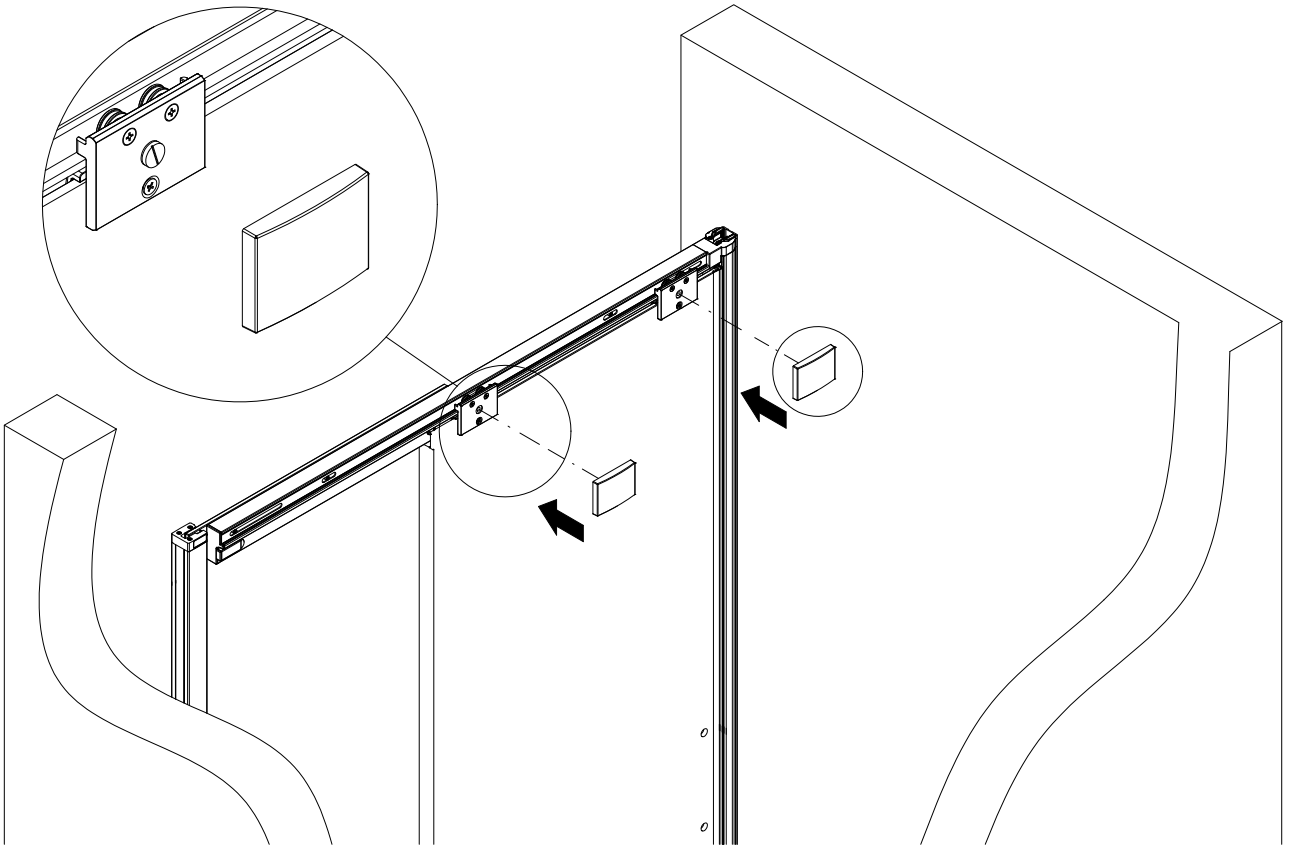

20

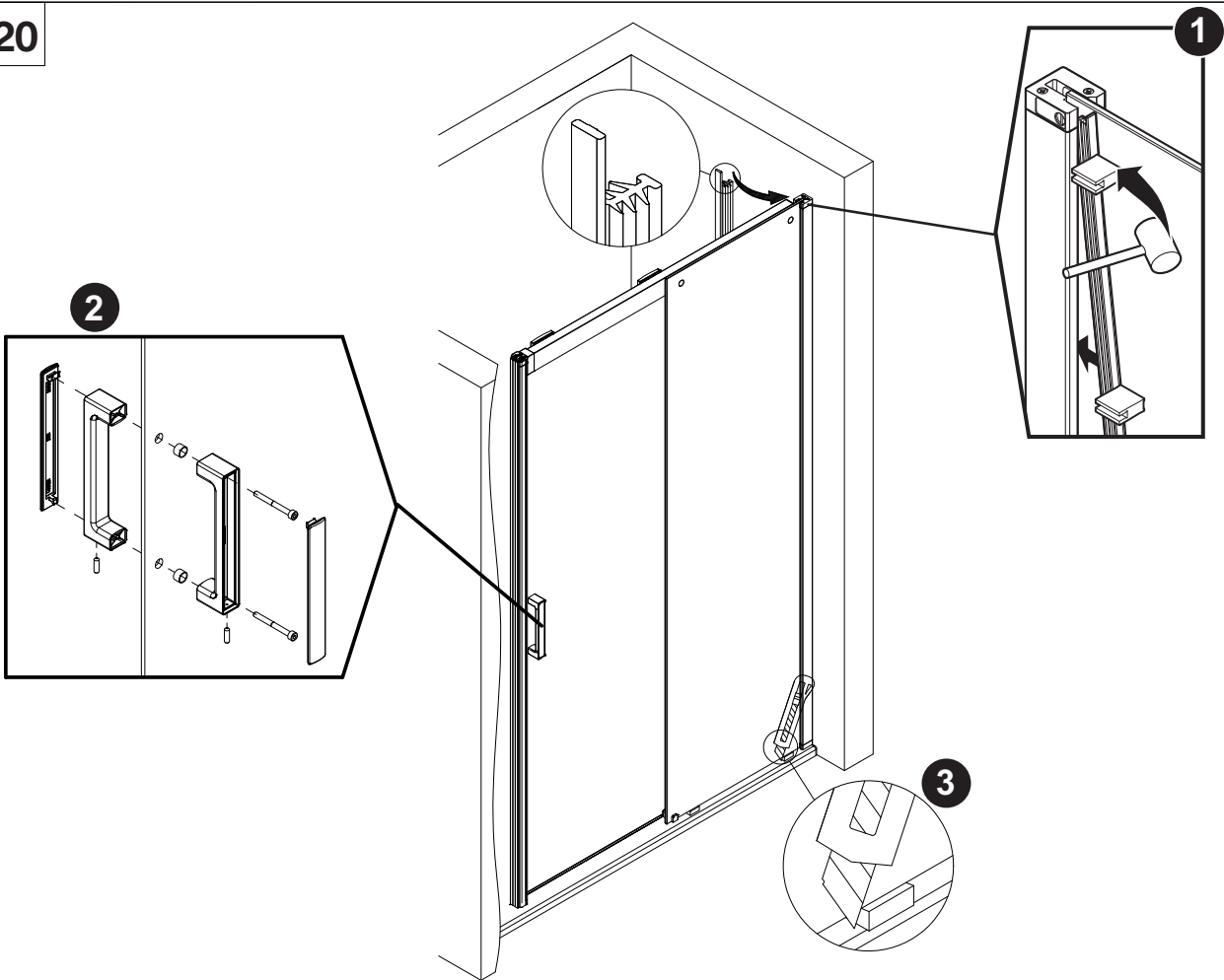

21

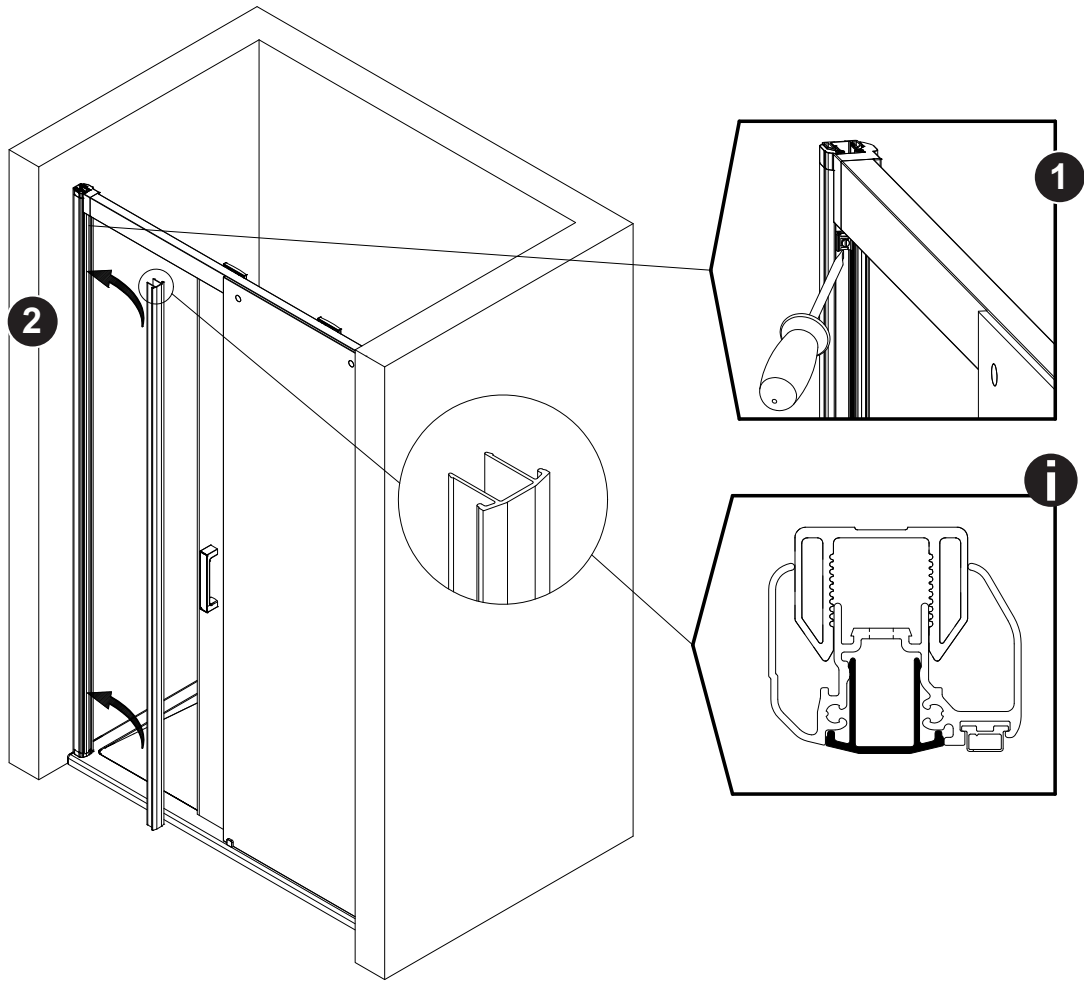

22

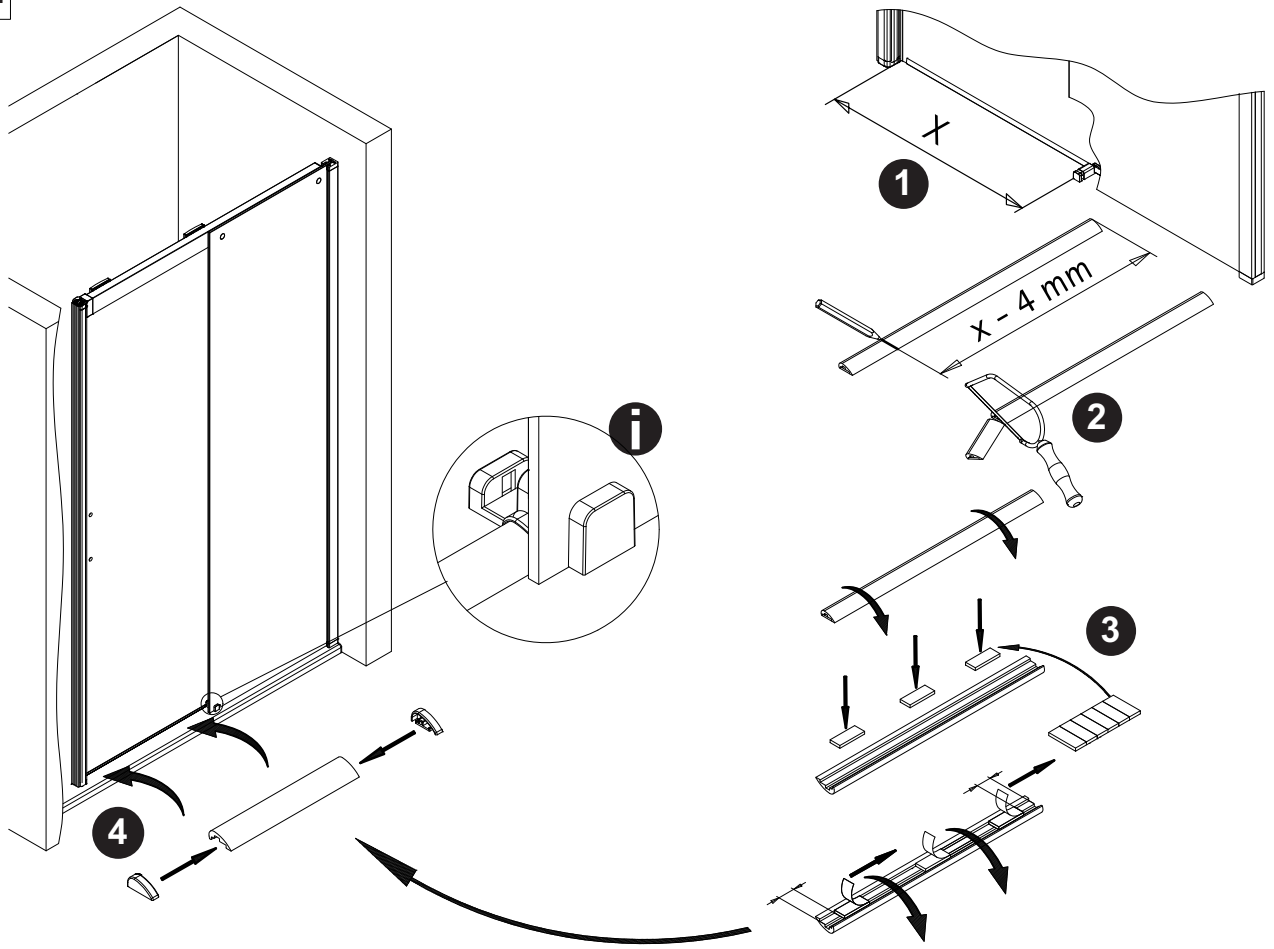

23

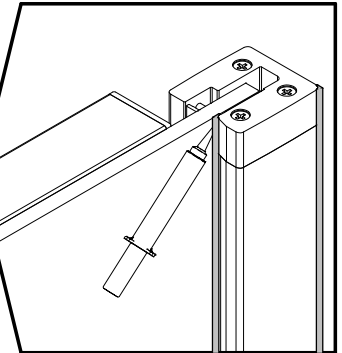
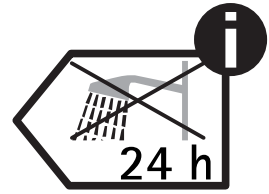
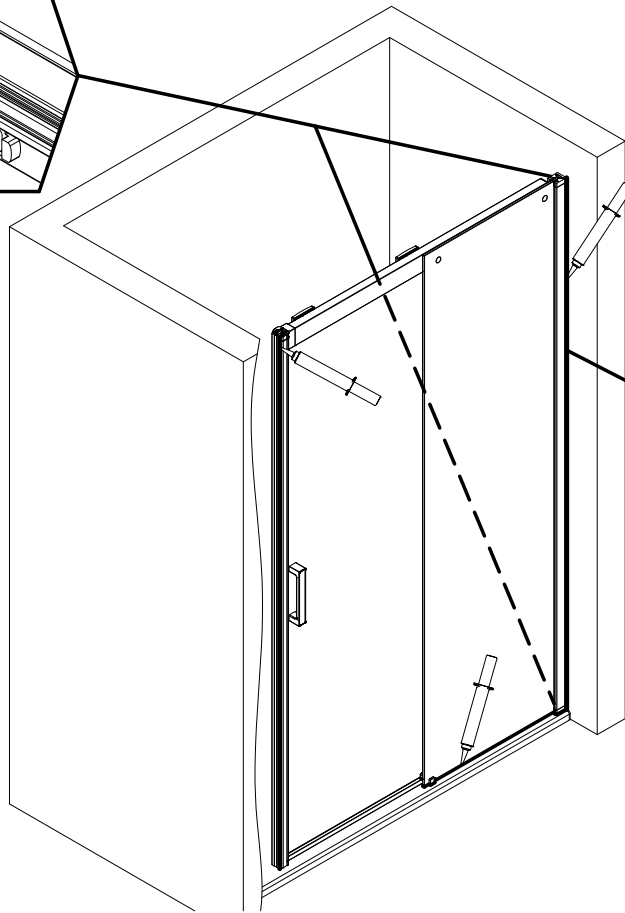
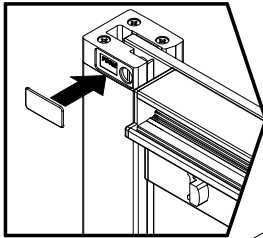

24

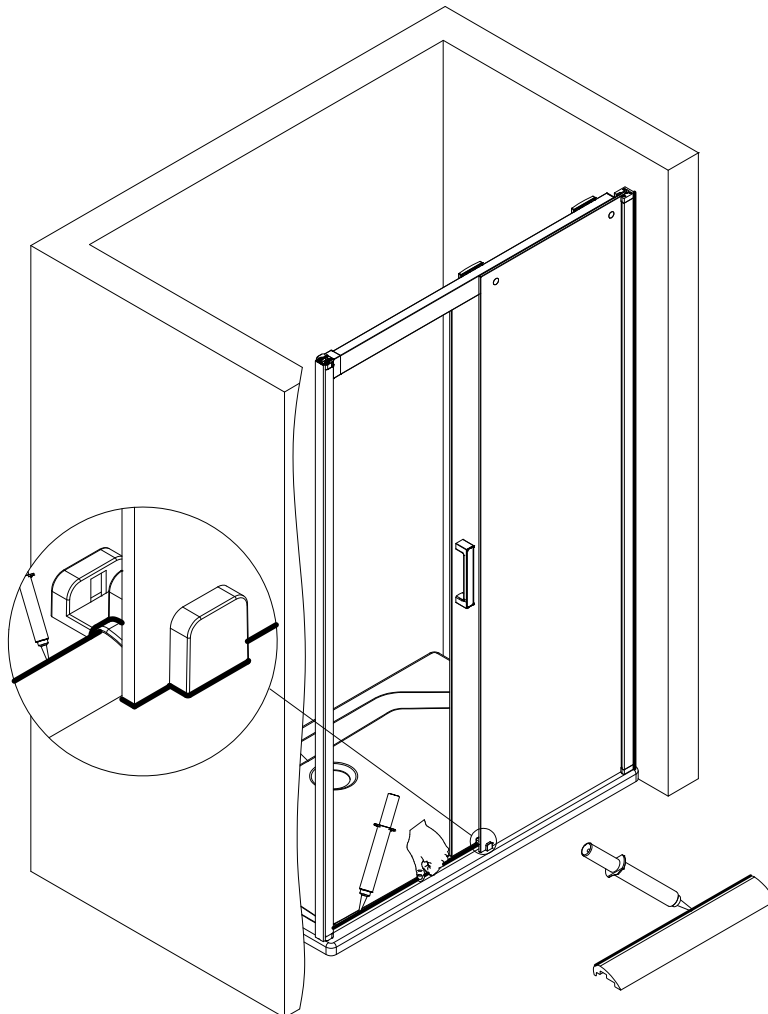
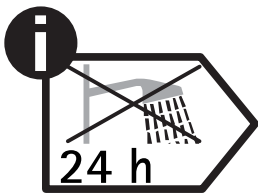

<< Checkliste >> für die Montage der Schiebetür

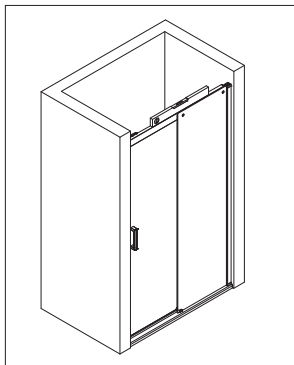
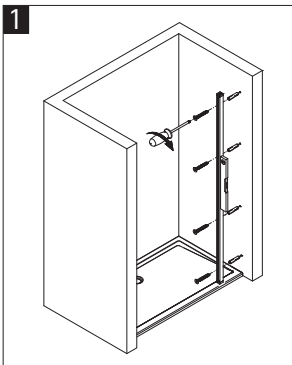

Das Glaselement, Profile und die obere Schiene / Schiebetür sollte im rechten Winkel aufgestellt werden.

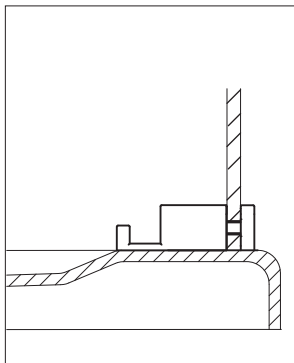
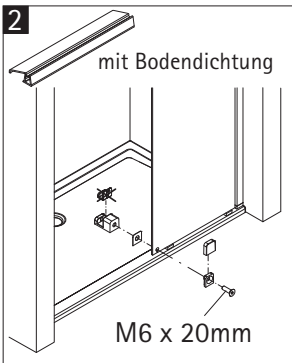

Die untere Türführung ordnungsgemäß installieren. Danach liegt Sie komplett auf.

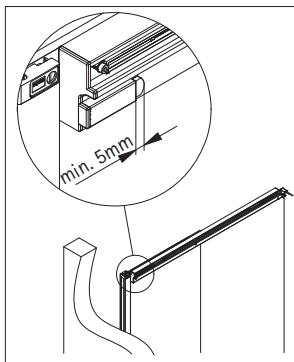
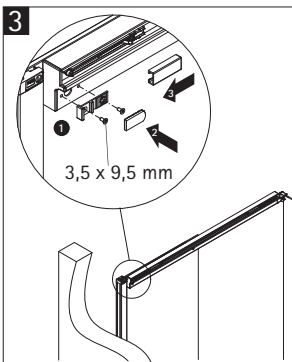

Stopper montieren. Das Gummi muss mindestens 5 mm herauschauen.

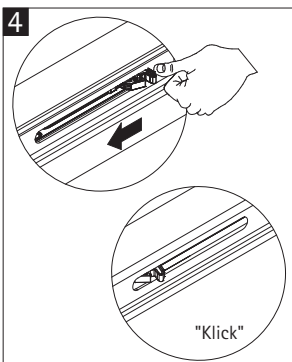

Achten Sie darauf das der Softclose-Mechanismus aktiviert ist.

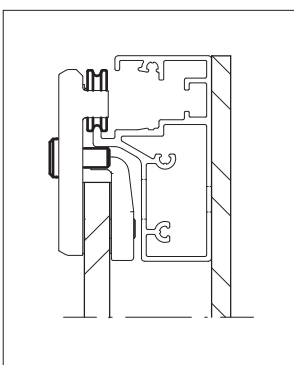
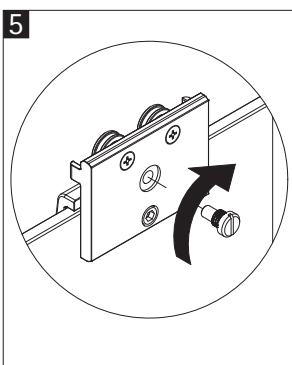

Ist die Sicherungsschraube montiert?

Wenn die Sicherungsschraube nicht montiert wird kann die Türscheibe aus der Führung springen und zerbrechen.

F << checklist >>

Points de vérification de sécurité pour montage porte coulissante

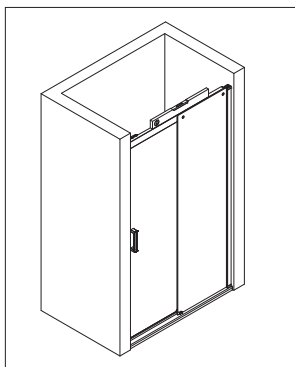
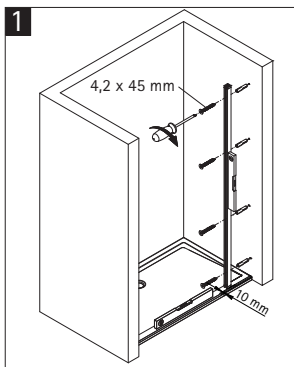

Les éléments en verre, les profilés et le rail haut et la glissière doivent être montés à plomb / au niveau.

Remettre le No. des schémas de la notice

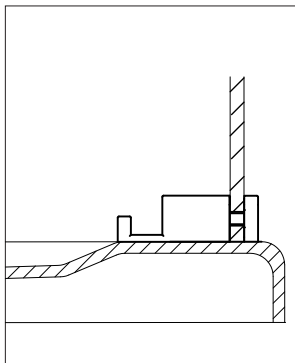
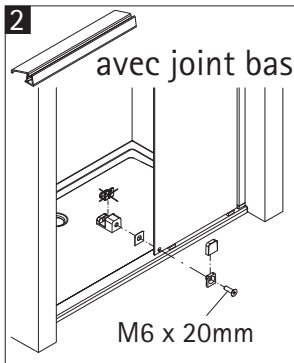

Le guide de porte en bas doit être monté correctement et doit reposer complètement sur le bord du receveur / sur le carrelage.

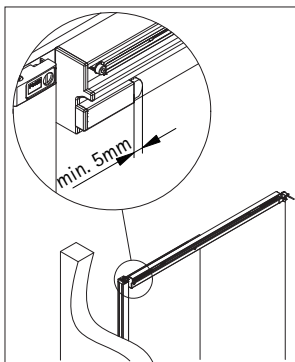
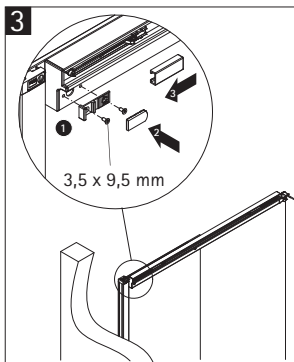

Les pièces d'arrêt doivent être correctement montées.

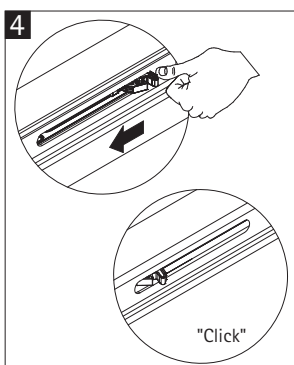

Le bon état du ralentisseur doit être contrôlé.

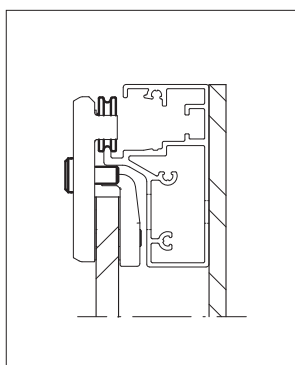
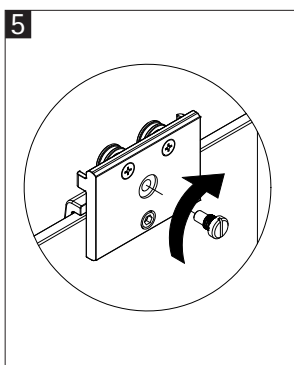

Vous avez entièrement serré les vises de sécurité?

Si les vises de sécurité ne sont pas entièrement serrées, l'élément mobile peut sortir du rail et casser !

<< Checklijst >> voor montage schuifdeur

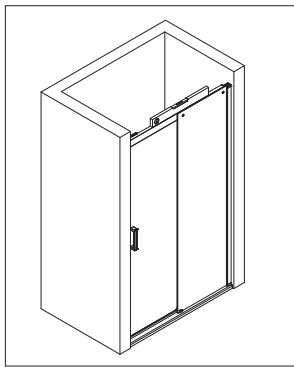
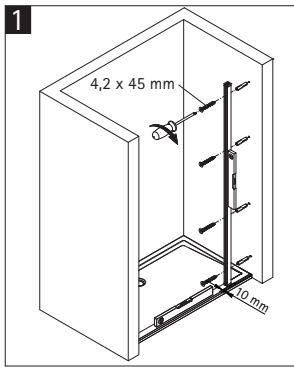

De glazen elementen, de profielen en de bovenrail / schuifdeur moet loodrecht worden geplaatst.

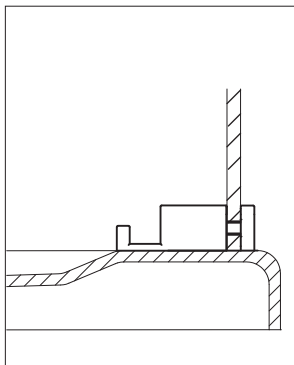
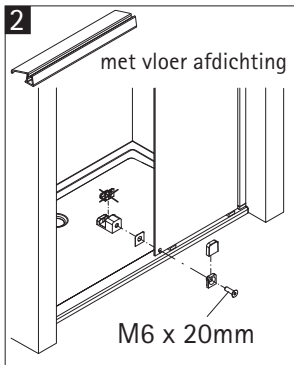

De onderste deurgeleiding moet correct worden gemonteerd en moet in zijn geheel rusten op de bak of tegelvloer.

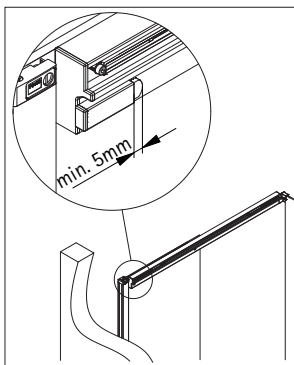
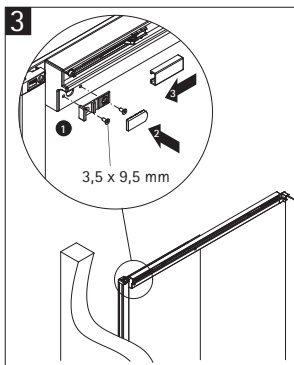

De deurstoppers moeten correct worden gemonteerd.

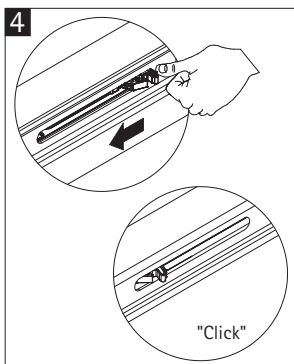

De werking van de softclose moet worden gecontroleerd.

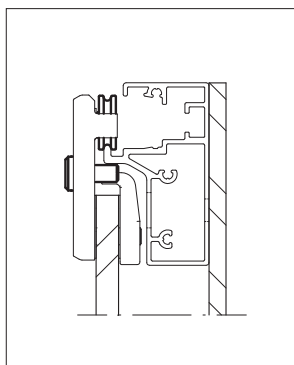
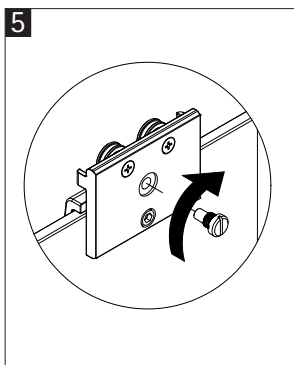

Zijn de veiligheidsschroeven goed vastgedraaid?

Als de veiligheidsschroeven niet goed zijn vastgedraaid, kan het schuifelement uit de rail lopen en breken!



D Wichtiger Hinweis:
Duschcabinen bitte vor dem Einbau auf Transportschäden und Vollständigkeit prüfen, da Beanstandungen nach dem Aufbau nicht mehr anerkannt werden können.

GB Important information:
Please check the shower enclosure for transport damage and completeness before installation. Complaints made following installation cannot be accepted.

F Remarque importante:
avant de procéder au montage, vérifiez que le pare douche est complet et qu'il n'a pas été endommagé lors du transport. Aucune réclamation ne pourra être admise après le montage.

NL Belangrijk:
Controleer voor het inbouwen of het douchescherm bij het transport beschadigd is en of het volledig is. Na het inbouwen kunnen klachten niet meer in behandeling genomen worden.

D Sicherheitshinweis:
Einscheiben-Sicherheitsgläser nie nachträglich bearbeiten.

GB Safety information:
Single pane, safety glass panels must not be reworked in any way following supply.

F Remarques concernant la sécurité:
Vous ne devez en aucune façon tenter de retailer les vitrages en verre sécurité.

NL Veiligheidsvoorschrift:
Gehard veiligheidsglas mag niet achteraf worden bewerkt.

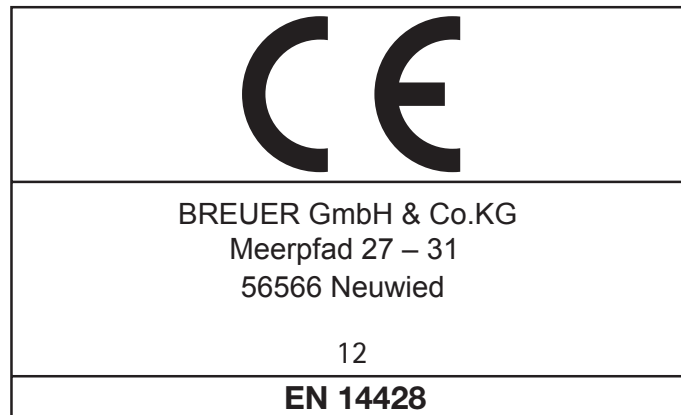

D	Duschabtrennung aus einem bestimmten Scheibenmaterial
Reinigbarkeit:	Bestanden
Bruchigenschaften:	Bestanden
Dauerhaftigkeit:	Bestanden

F	Paroi de douche dans un matériau vitré particulier
Nettoyabilité:	passé avec succès
Propriétés à la cassure:	passé avec succès
Durabilité:	passé avec succès

GB	Shower enclosure made of a specific plane material
Cleanability:	Passed
Fracture behaviour:	Passed
Durability:	Passed

NL	Douche-afschieding van bepaald ruitmateriaal
Reinigbaarheid:	Doorstaan
Bruekeigenschaften:	Doorstaan
Duurzaamheid:	Doorstaan

Dusch-Info
Meerpfad 27-31
D-56566 Neuwied
Tel: 02631-8607-0