

# LAUFEN

LFM-IV301  
LFM-OV302  
LFM-AW302

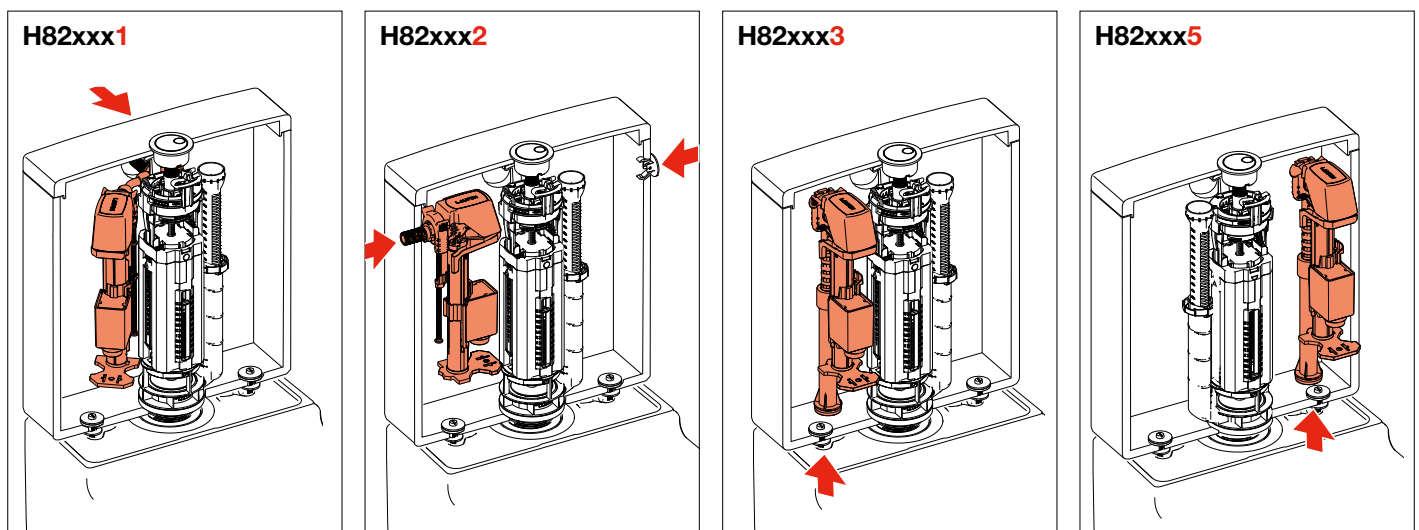
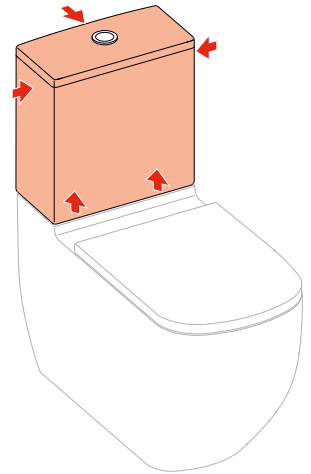

- DE** Diese Anleitung muss dem Benutzer ausgehändigt werden. Garantie/Haftung nur bei Montage gemäss Anleitung durch eine konzessionierte Fachkraft und gemäss örtlichen Vorschriften bei einem Druckbereich 0,5 – 10 bar.
- FR** Garantie/responsabilité uniquement assurées en cas de montage conforme au mode d'emploi, effectué par un spécialiste concessionnaire et en fonction des prescriptions locales dans des conditions de pression comprises entre 0,5 – 10 bars.
- IT** Garanzia/responsabilità assicurate soltanto in caso di montaggio conforme alle istruzioni per l'uso e eseguito da uno specialista concessionario in funzione delle prescrizioni locali con un campo di pressione di 0,5 – 10 bar.
- EN** Guarantee/Liability only when assembled by an approved specialist in accordance with the instructions and local regulations within the pressure range 0,5 – 10 bar.
- ES** Garantía/Responsabilidad sólo cuando está montado según las instrucciones de un profesional autorizado y de conformidad con la normativa local en el rango de presión 0,5 – 10 bar.
- NL** Garantie/aansprakelijkheid enkel bij montage volgens de handleiding door een bevoegde vakman en volgens de lokale voorschriften bij drukbereik 0,5 – 10 bar.
- CS** Garance/záruka pouze při montáži, prováděné dle návodu osobou odborně způsobilou s příslušnou koncesí a dle předpisů platných v místě a při tlaku v rozmezí od 0,5 do 10 barů.
- LT** Garantija / turtinė atsakomybė suteikiama, jei montavimą pagal instrukciją atlieka kvalifikuotas specialistas pagal vietinius reikalavimus reikalavimus esant 0,5 – 10 barų slėgio diapazonui.
- PL** Gwarancja/odpowiedzialność prawna wyłącznie w przypadku montażu wykonanego przez upoważnionego specjalistę zgodnie z instrukcją oraz lokalnymi przepisami w zakresie ciśnienia od 0,5 do 10 bar.
- HU** Garancia/felelősség csak engedéllyel rendelkező szakember által végrehajtott, az útmutatásnak és a helyi előírásoknak megfelelő szerelés esetén, 0,5 – 10 baros nyomástartományban.
- RU** Гарантия действительна только в том случае, если монтаж выполнен специалистом согласно инструкции и с учетом местных предписаний при диапазоне давления 0,5 – 10 бар.
- BG** Гаранция / отговорност само при монтаж в съответствие с ръководството от лицензиран специалист и в съответствие с местните разпоредби за диапазон на налягането 0,5 – 10 бара.
- DA** Denne vejledning skal udleveres til brugeren. Garantien gælder kun, hvis monteringen udføres af en autoriseret fagmand, der følger vejledningen og overholder de lokale bestemmelser ved et trykkræde på 0,5 – 10 bar.
- SV** Denna anvisning måste överlämnas till användaren. Garanti/ersättningskyldighet gäller endast om monteringen har genomförts enligt anvisningen av en auktoriserad specialist och enligt de lokala föreskrifterna på tryckområdet 0,5 – 10 bar.
- NO** Denne veiledningen må utleveres til brukeren. Garanti/erstatningsansvar kun hvis monteringen er utført av en fagperson med konsesjon i henhold til veiledning og i samsvar med lokale forskrifter ved et trykk på 0,5 til 10 bar.
- FI** Tämä ohje täytyy antaa käyttäjälle. Takuu/tuotevastuu vain, kun asennuksen suorittaa toimiluvan omaava ammattilainen käyttööhejen sekä paikallisten 0,5 – 10 baarin painealuetta koskevien määräysten mukaisesti.
- SK** Tento návod musí byť doručený používateľovi. Záruka platí, len ak sa montáž vykoná podľa návodu a ak ju vykoná odborník s oprávnením v súlade s miestnymi predpismi, a to pri rozsahu tlaku 0,5 – 10 bar.
- ZH** 必须将本说明书当面交给用户。保修/责任仅在遵照说明书，并由授权专业人员符合当地法规且在压力区间 0.5 - 10 bar 内操作时生效
- ET** See juhend tuleb kasutajale anda. Garantii kehtib ainult juhul, kui seade on paigaldatud kasutusjuhendi järgi, seda on teinud liitsentsiga spetsialist ning järgitud on kohalikke eeskirju ja paigaldatud on rõhuvahemikus 0,5–10 baari.
- HR** Ove se upute moraju predati korisniku. Garancija/odgovornost vrijedi samo ako je montažu izvršilo ovlašteno stručno osoblje prema uputama i lokalnim propisima pri rasponu tlaka od 0,5 do 10 bara.
- LV** Šis instrukcijas ir jānodod lietotājam. Garantija ir spēkā tikai tad, ja licencēts speciālists uzstādīšanu veic atbilstoši vietējiem noteikumiem un 0,5–10 bar spiediena intervālā.
- PT** O presente manual deve ser entregue ao utilizador. Garantia/responsabilidade apenas no caso de montagem realizada por um técnico concessionado e segundo os regulamentos locais, com uma gama de pressão de 0,5 – 10 bar.
- TR** Bu kılavuz kullanıcınıza verilmelidir. Garanti/sorumluluk, sadece ürün 0,5 – 10 bar basınç aralığında kılavuzda öngörülen şekilde yetkili uzman personel tarafından ve yerel yönetmeliklerde öngörülümü şeklide monte edilginde geçerlilik kazanır.
- SR** Garantni list /Garancija / odgovornost samo ako ih montira ovlašćeno lice u skladu sa uputstvima i lokalnim propisima u opsegu pritiska 0,5 - 10 bara.
- SL** Garancija / Odgovornost velja samo v kolikor montirano s strani stokovnega osebja, v kolikor v skladu z navodili za montažo, v kolikor so upoštevani lokalni veljavni predpisi in v kolikor je pritisk vode med 0,5 - 10 bara.

Lieferumfang  
 Contenu du colis  
 Distinta dei pezzi  
 Parts list  
 Alcance del suministro

Toebehoren  
 Rozsah dodávky  
 Dalių sąrašas  
 Zakres dostawy  
 Szállítási terjedelem

Комплекция  
 Списък на детайлите  
 Leveringsomfang  
 供货范围  
 Leveransomfang

Toimituskokonaisuus  
 Obsah dodávky  
 Osade nimekiri  
 Popis dijelova

Daļu saraksts  
 Lista de peças  
 Parça listesi  
 Lista delova  
 Seznam delov

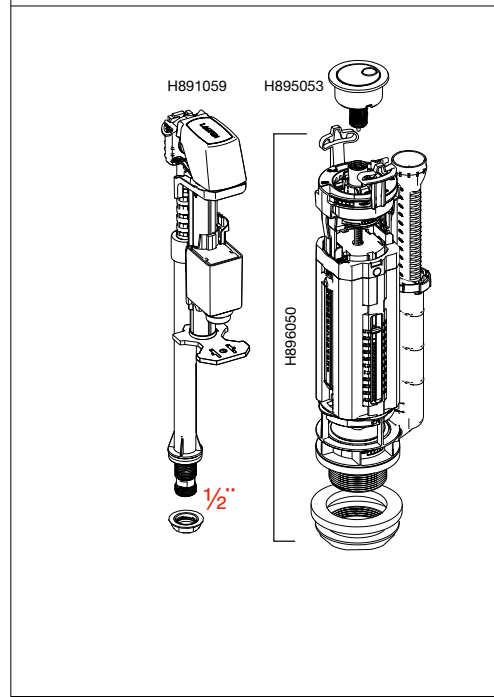
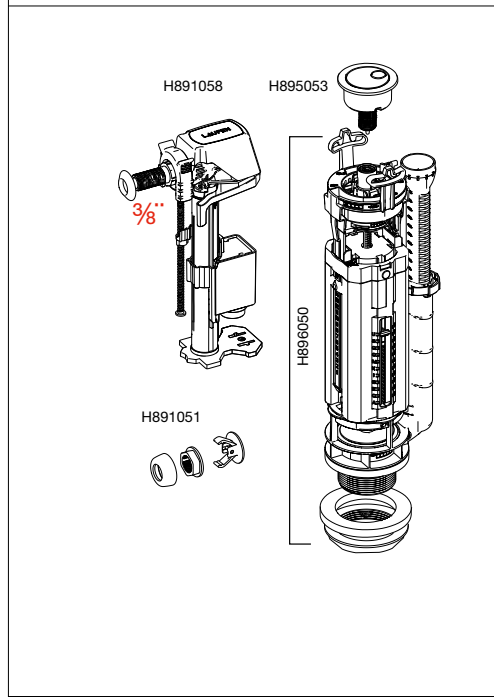
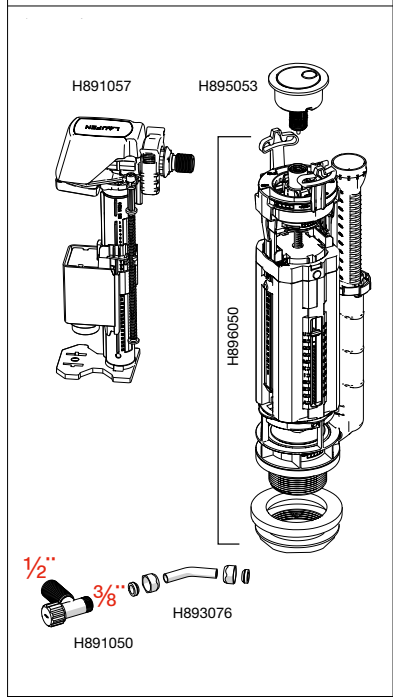
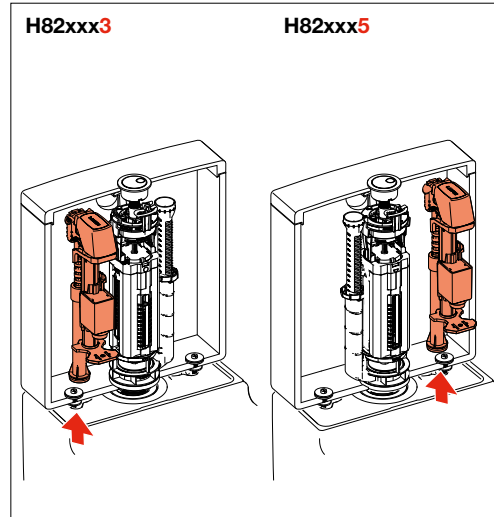
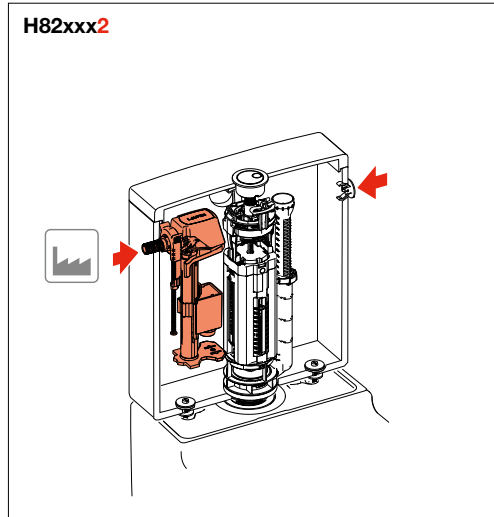
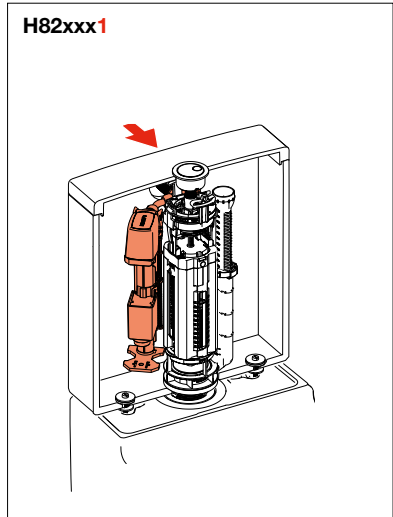

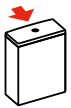

Montageablauf  
Exécution du montage  
Esecuzione del montaggio  
Assembly procedure  
Proceso de montaje

Montageverloop  
Průběh montáže  
Montavimo tvarka  
Odpyw montażowy  
A szerelés menete

Последовательность монтажа  
Протичане на монтажа  
Monteringstrin  
Monteringsprocedur  
Monteringsbeskrivelse

Asennuksen  
Montáž  
装配程序  
Kokkumonteerimine  
Postupak montaže

Montāžas procedūra  
Processo de montagem  
Montaj prosedūrū  
Uputstvo za montažu  
Navodila za montažo

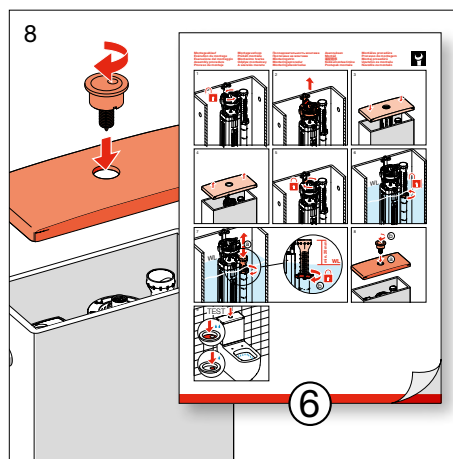
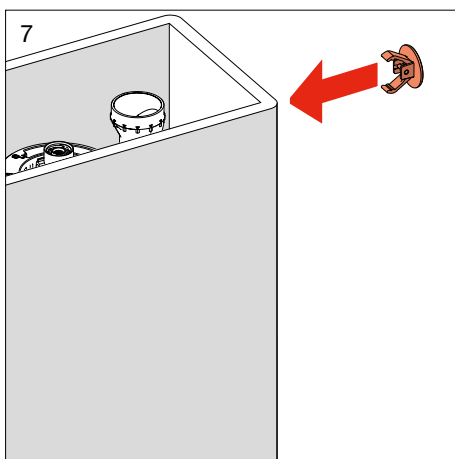
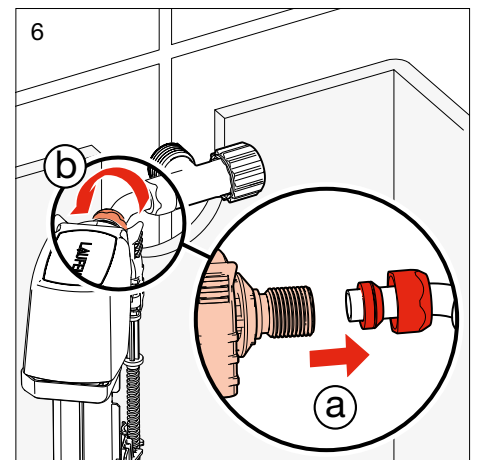
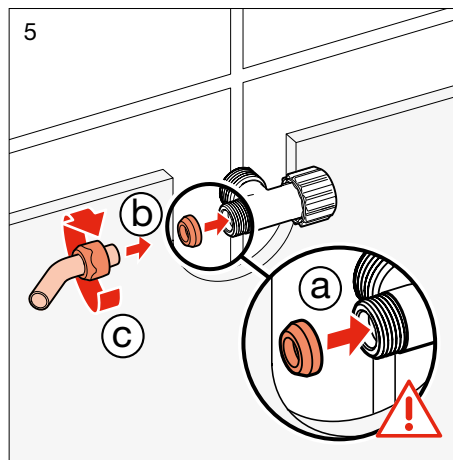
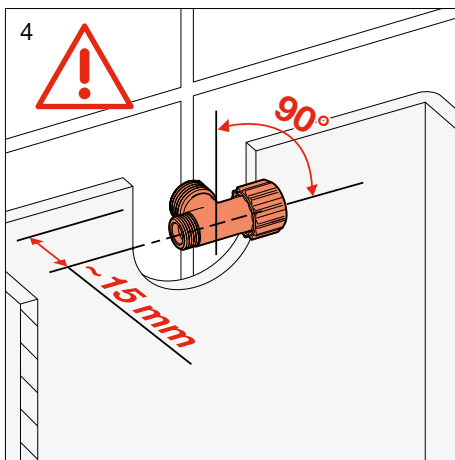
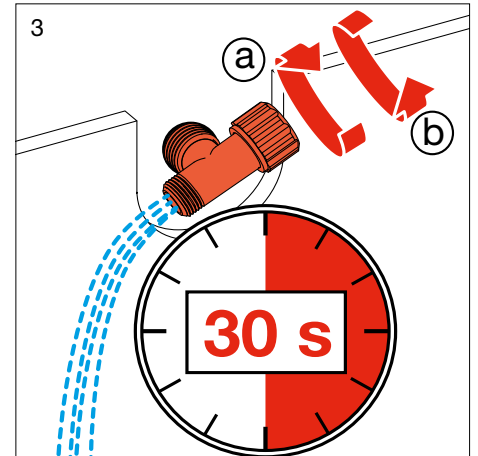
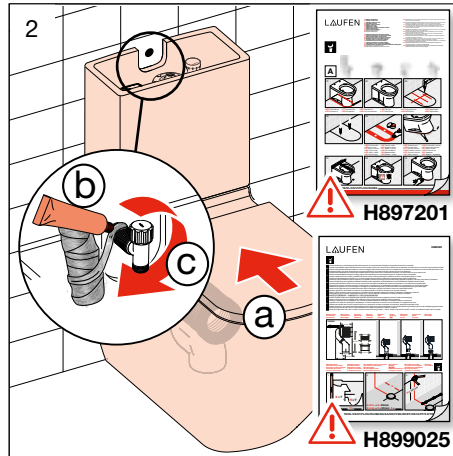
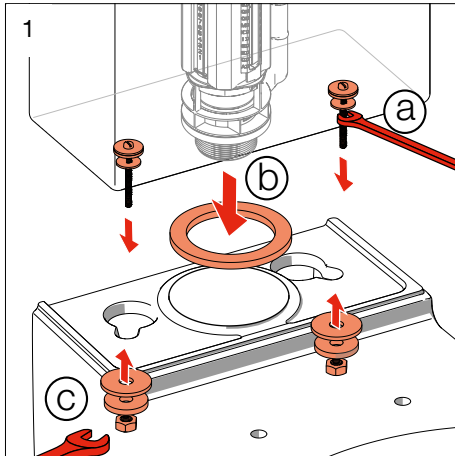

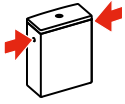

**Montageablauf**  
 Exécution du montage  
 Esecuzione del montaggio  
 Assembly procedure  
 Processo de montaje

**Montageverloop**  
 Průběh montáže  
 Montavimo tvarka  
 Odplyw montażowy  
 A szerelés menete

**Последовательность монтажа**  
 Протичане на монтажа  
 Монтерингстрин  
 Monteringsprocedur  
 Monteringsbeskrivelse

**Asennuksen**  
 Montáž  
 裝配程序  
 Kokkumonteerimine  
 Postupak montaže

**Montāžas procedūra**  
 Processo de montagem  
 Montaj prosedürü  
 Uputstvo za montažu  
 Navodila za montažo

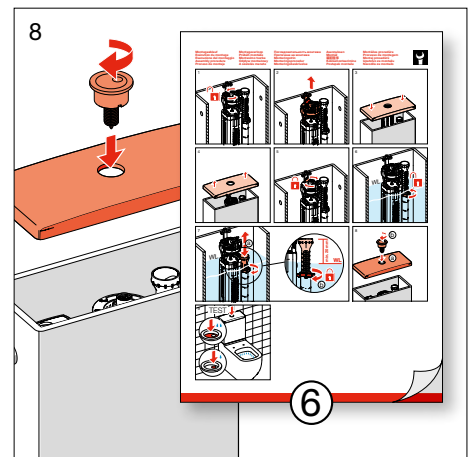
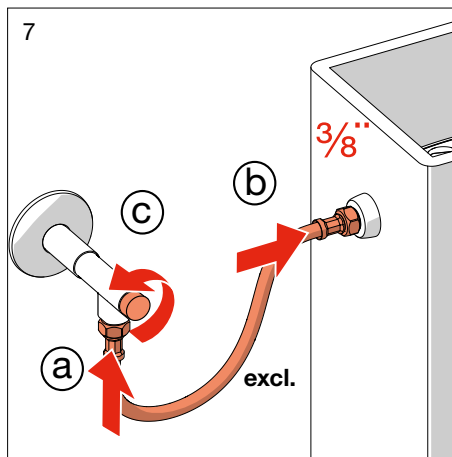
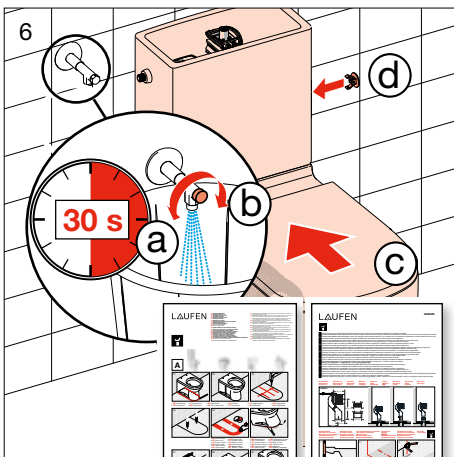
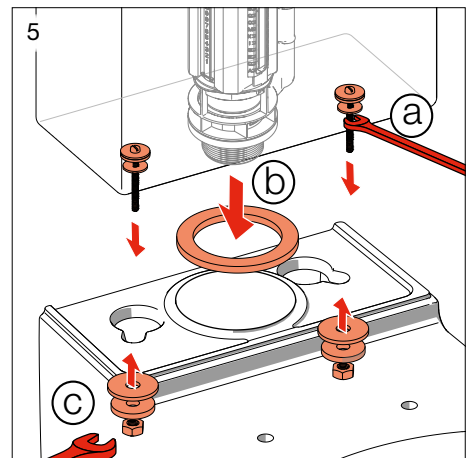
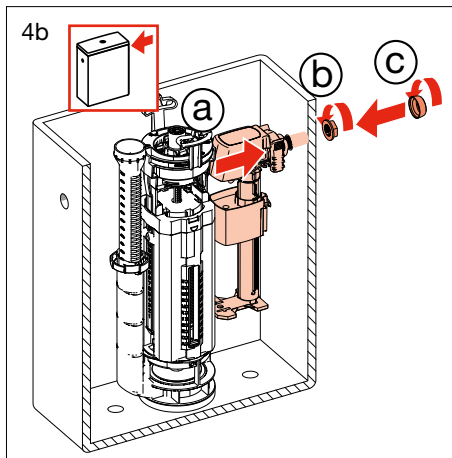
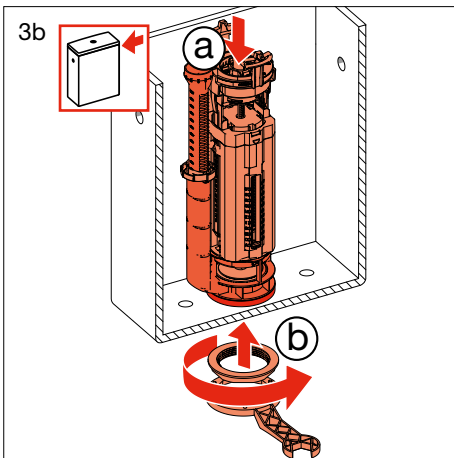
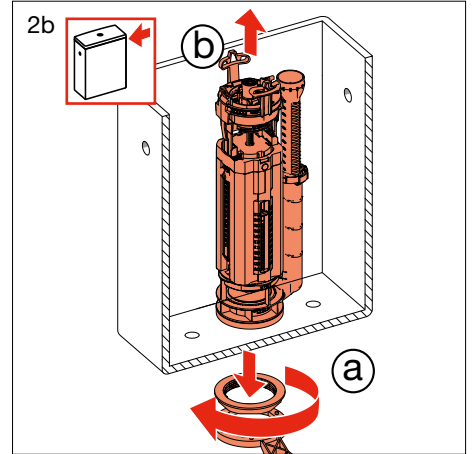
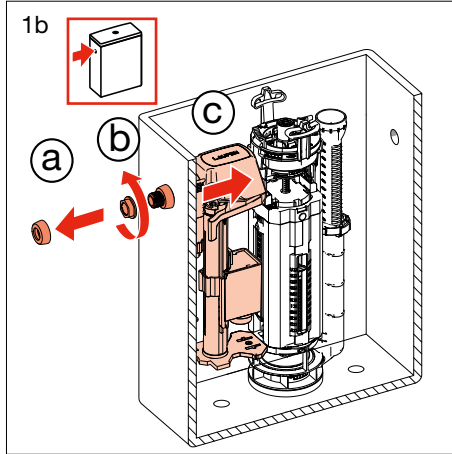
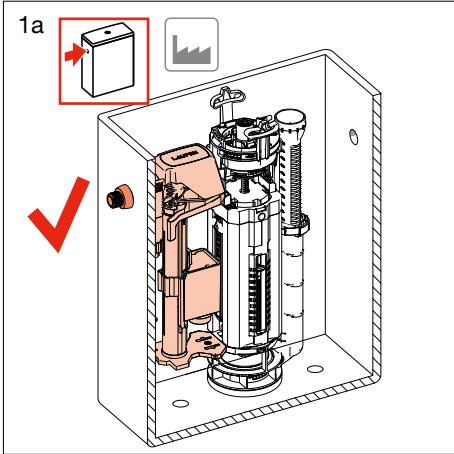

H897201 H899025



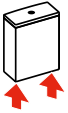

Montageablauf  
Exécution du montage  
Esecuzione del montaggio  
Assembly procedure  
Proceso de montaje

Montageverloop  
Průběh montáže  
Montavimo tvarka  
Odpływ montażowy  
A szerelés menete

Последовательность монтажа  
Протичане на монтажа  
Monteringstrin  
Monteringsprocedur  
Monteringsbeskrivelse

Asennuksen  
Montáž  
裝配程序  
Kokkumonteerimine  
Postupak montaže

Montāžas procedūra  
Processo de montagem  
Montaj prosedūru  
Uputstvo za montažu  
Navodila za montažo

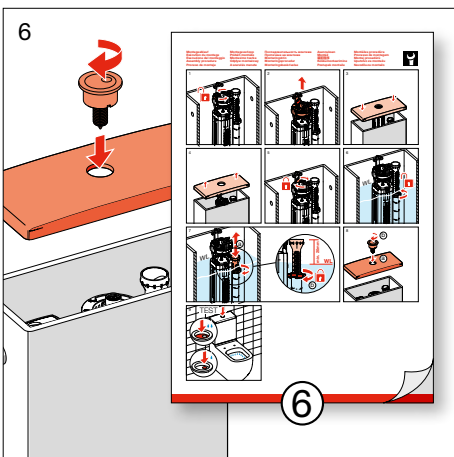
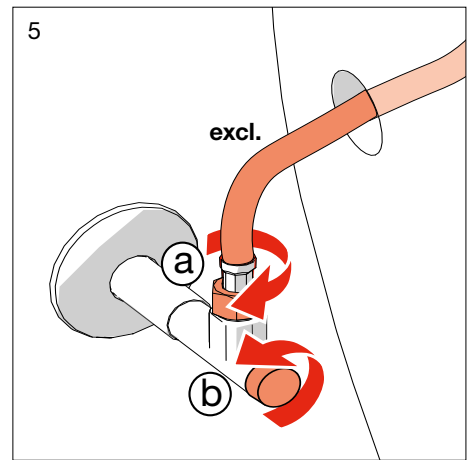
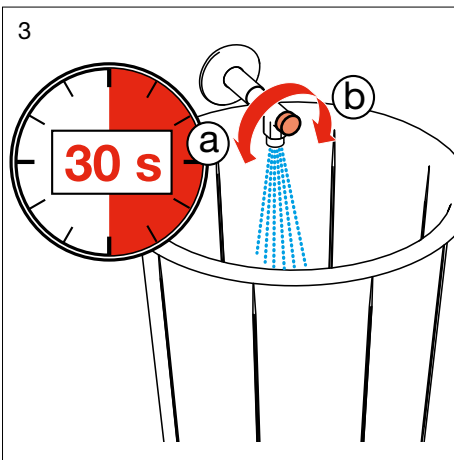
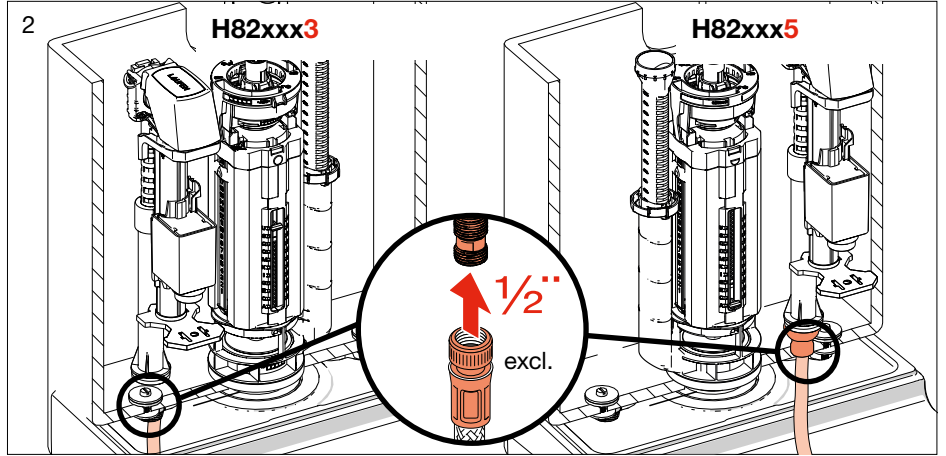
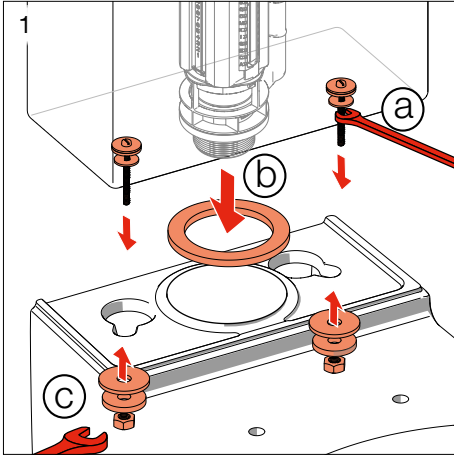

Montageablauf  
 Exécution du montage  
 Esecuzione del montaggio  
 Assembly procedure  
 Processo de montaje

Montageverloop  
 Průběh montáže  
 Montavimo tvarka  
 Odplyw montażowy  
 A szerelés menete

Последовательность монтажа  
 Протичане на монтажа  
 Monteringstrin  
 Monteringsprocedur  
 Monteringsbeskrivelse

Asennuksen  
 Montáž  
 装配程序  
 Kokkumonteerimine  
 Postupak montaže

Montāžas procedūra  
 Processo de montagem  
 Montaj prosedürü  
 Uputstvo za montažu  
 Navodila za montažo

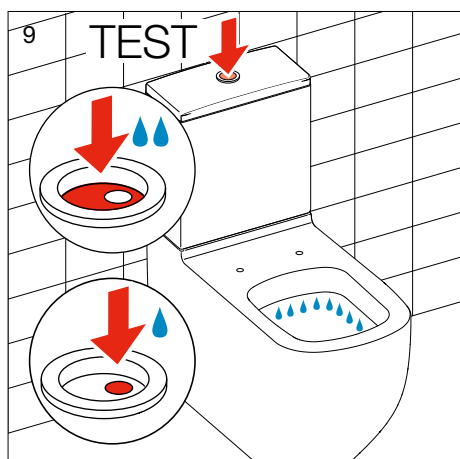
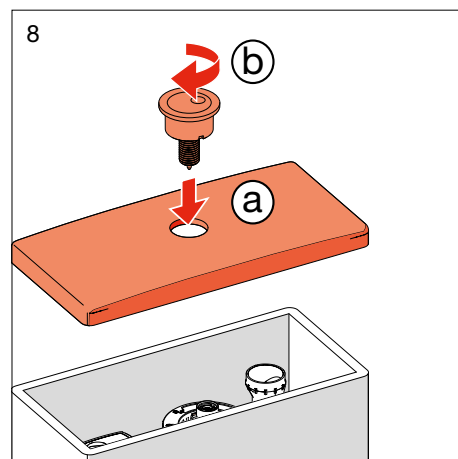
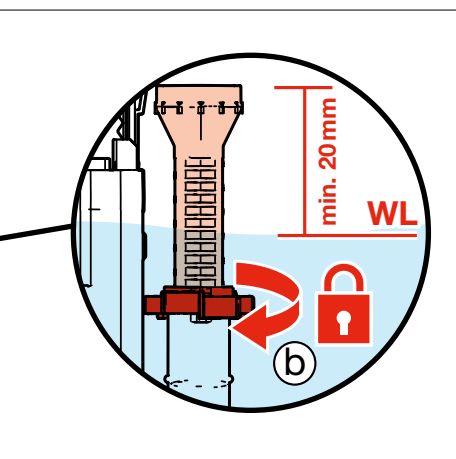
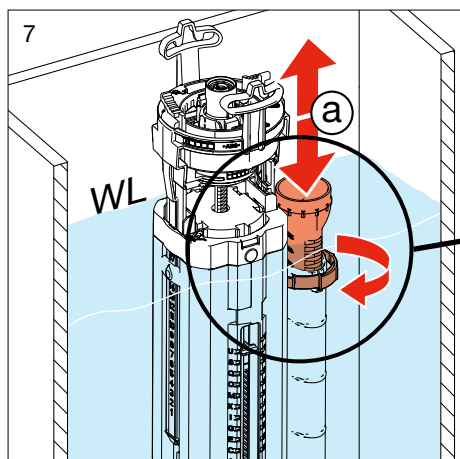
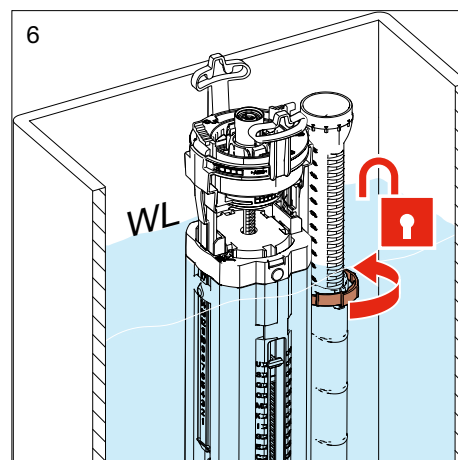
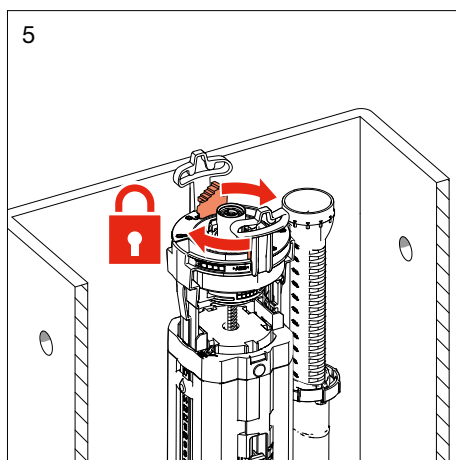
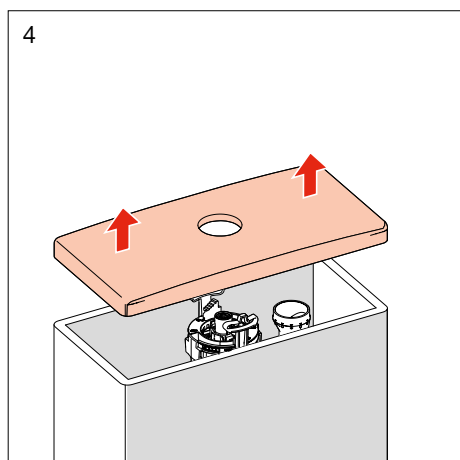
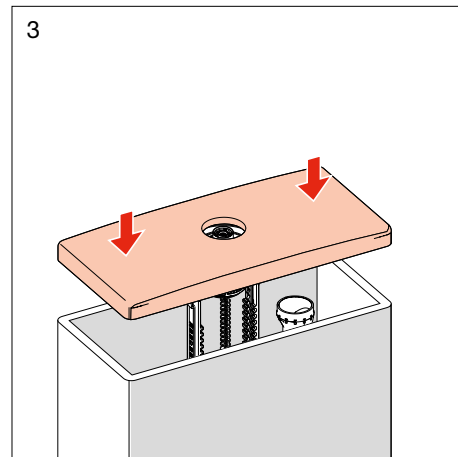
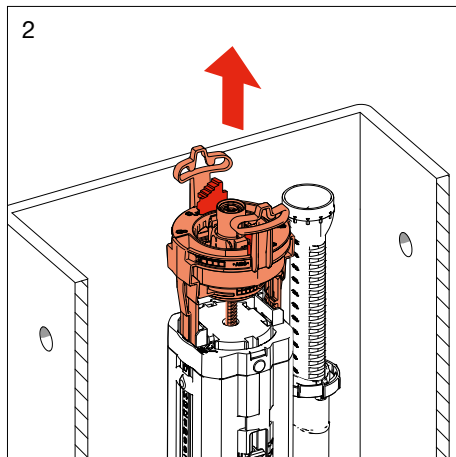
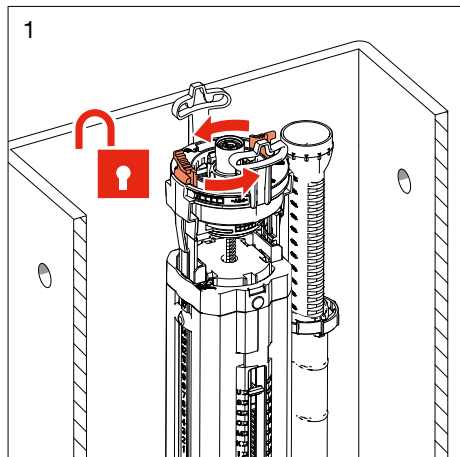

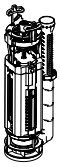

Service  
Service  
Servicio  
Service  
Servicio

Service  
Servis  
Aptarnavimas  
Serwis  
Karbantartás

Обслуживание  
Обслужване  
Service  
Service  
Service

Huolto  
Servis  
售后服务  
Hooldus  
Servis

Apkove  
Assistència  
Servis  
Servis  
Servis

Service

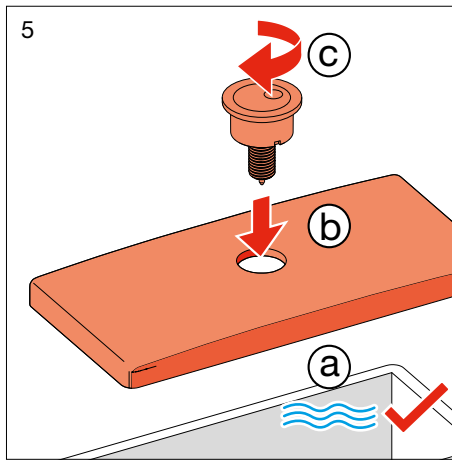
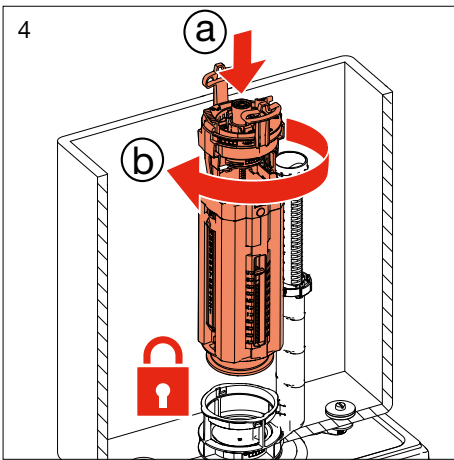
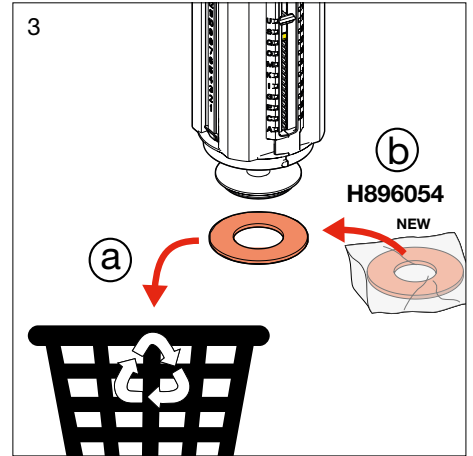
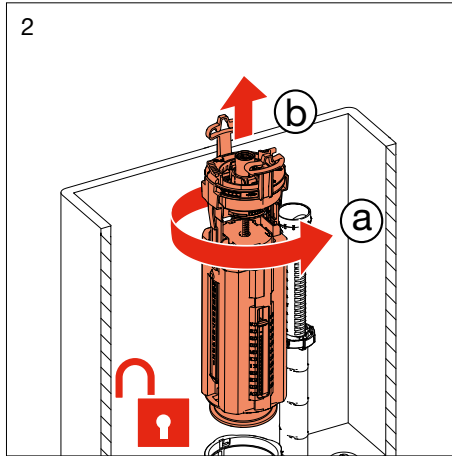
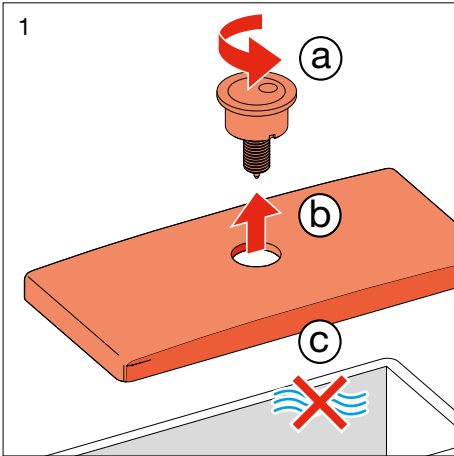

Verstellen der Spülmenge  
Réglage de la quantité d'eau de rinçage  
Modifica del volume di scarico  
Setting the flush volume  
Ajustar el tiempo de cantidad de lavado  
Instellen van de spoelhoeveelheid  
Regulace splachovacieho množství

Plovimui naudojamo vandens kiekio reguliavimas  
Regulacja ilości płukania  
Обітєси mennyiség beállítása  
Регулировка расхода воды для смыва  
Регулиране на количеството

на промиване  
Justering af skyllevolume  
Ställa in flush volym  
Innstilling av spylemengde  
Huuhtelu asettaminen  
Prestavitev množstva splachovaneje vody  
調整冲洗量

Loputuskoguse reguleerimine  
Postavljanje količine za ispiranje  
Skalošanas daudzuma maiņa  
Regulação do volume de descarga  
Su boşaltma miktarının ayarlanması  
Poděšavanje količine ispiranja  
Nastvitev količine izpiranja

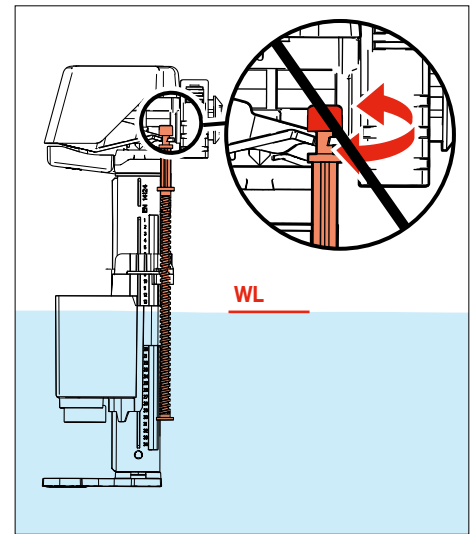
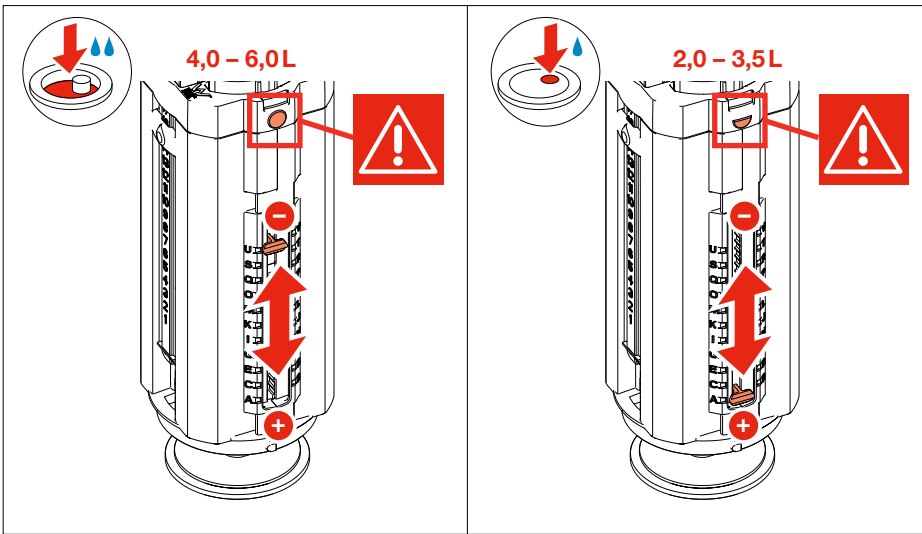

SET	RIMLESS	5L				3L				6L				4.5L			
		5L	3L	6L	4.5L	5L	3L	6L	4.5L	5L	3L	6L	4.5L	5L	3L	6L	4.5L
Kartell   LAUFEN	X	F	Q	C	I	F	Q	C	H	H	R	D	J				
LAUFEN PRO	X	F	Q	C	I	F	Q	C	H	H	R	D	J				
LAUFEN PRO						I	U	F	K	I	T	E	J	J	U	F	K
LAUFEN PRO B						E	M	C	G	F	M	C	G	F	N	C	H
LUA	X	E	Q	B	H	E	Q	B	G	G	Q	C	I				
THE NEW CLASSIC	X	F	Q	C	I	F	Q	C	H	H	R	D	J				
VAL	X	F	Q	C	I	F	Q	C	H	H	R	D	J				
MODERNA R	X	C	M	A	E	C	M	A	E	C	M	A	E				
MODERNA R						G	P	C	-	-	-	-	-				
PALACE						E	O	B	F	F	O	B	G				
PALOMBA						E	P	C	G	E	P	C	H				
PALOMBA COLLECTION / INO	X	C	N	A	E	C	N	A	E	C	N	A	E				

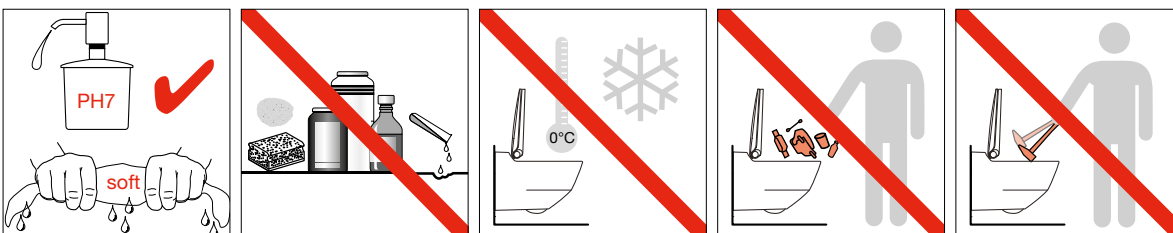

# LAUFEN

Laufen Bathrooms AG  
Wahlenstrasse 46  
CH-4242 Laufen, Switzerland  
www.laufen.com

16.05.2022 / H895161 / MYS  
MI01\_Tank\_rc\_sc\_bc\_GLOBAL