

FAR TOOLS®



REX 80
Professional Machine



© FAR GROUP EUROPE

- FR** Rénovateur compact (Notice originale)
EN Compact renovator (Original manual translation)
DE Kompakter Renovierungsschleifer (Übersetzung aus dem Original-Anleitung)
ES Renovador compacto (Traducción del manual de instrucciones originale)
IT Rinnovatore compatto (Traduzione dell'avvertenza originale)
PT Renovador compacto (Tradução do livro de instruções original)
NL Compacte renovatie (Vertaling van de originele instructies)
EL Συμπάγής ανακαινιστή (Μετάφραση από τις πρωτότυπες οδηγίες)
PL Kompaktowy remont (Tłumaczenie z oryginalnej instrukcji)
FI Kompakti hiomakone (Käännös alkuperäisestä käyttöohjeesta)
SV Kompakt renoverare (Översättning från originalinstruktioner)
BU Компактен ремонт (Превод на оригиналната инструкция)
DA Kompakt renovering (Oversættelse fra oprindelige brugsanvisning)
RO Renovator compact (Traducere din instrucțiunile originale)
RU **Компактный ремонт (Перевод с оригинальной инструкции)**
TU Kompakt renovator (Orijinal talimatlar çeviri)
CS Kompaktní restaurátor (Překlad z originálního návodu)
SK Kompaktný reštaurátor (Preklad z originálneho návodu)
HE בקמ שיטפ קומפקטית
AR مُرَمِّم مدمج (تعليمات أصلية)
HU Felújító kompakt (Fordítás az eredeti utasítások)
SL Obnovitelj Kompakten (Prevod iz izvornih navodil)
ET Renoveerija kompaktne (Tõlge originaal juhiseid)
LV Renovators kompakts (Tulkojumā no instrukcijas oriģinālvadodā)
LT Renovatorius kompaktiškas (Vertimas iš originalių instrukcijas)
HR Renovator kompaktni (Prijevod prema originalne upute)



115018-Manual-F-20230425



fartools.com



VIDEO DÉMONSTRATION DEMONSTRATION

Flashez le code ci contre,
ou rendez vous sur l'adresse suivante :

Flash the code below,
or go to the following address:



<https://www.fartools.com/r-novateur-compact-boutique-1700-1701-0-6687.html#gallery-photo-2>



Description et repérage des organes de la machine
Description and location of machine parts

A



Contenu du carton
Contents of box

C



Points de collecte sur www.quefaire-demmesdechets.fr
Privilégiez la réparation ou le don de votre appareil !





Assemblage de la machine
Machine assembly

D

02

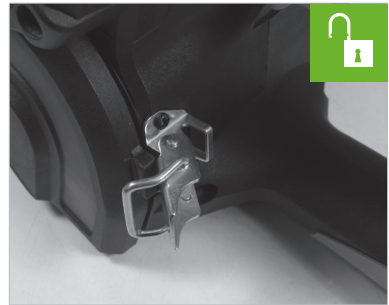
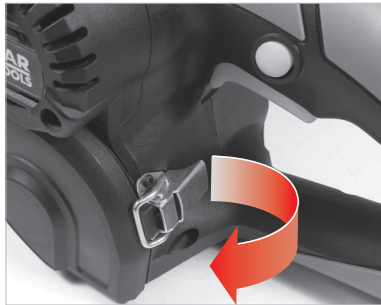
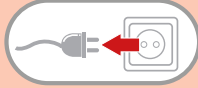

03

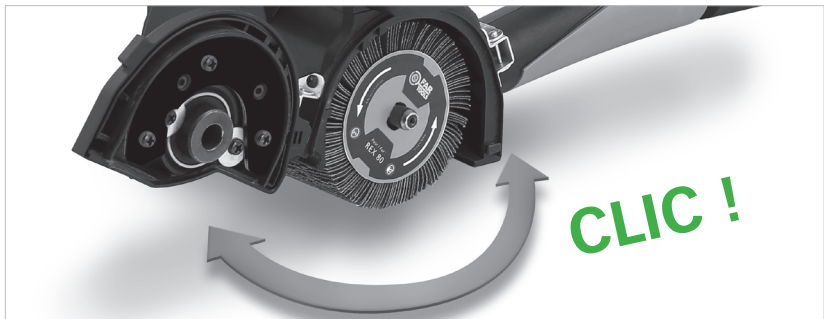
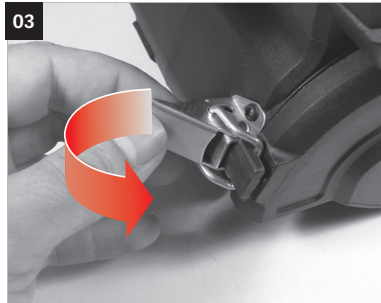

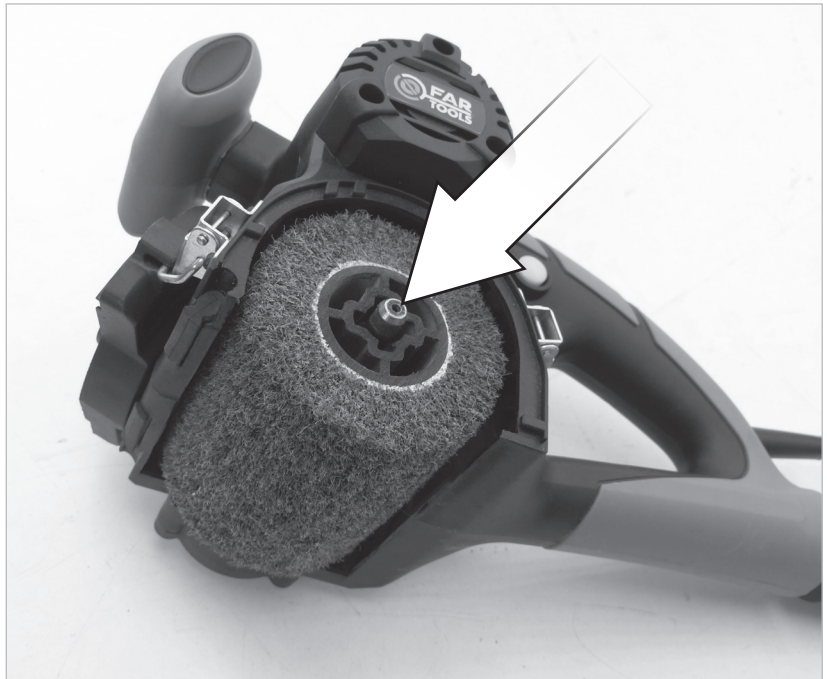
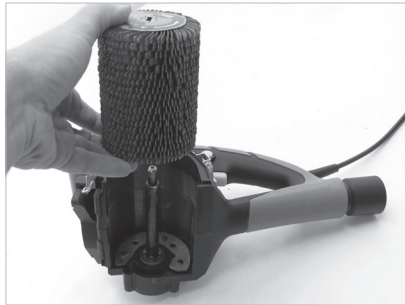
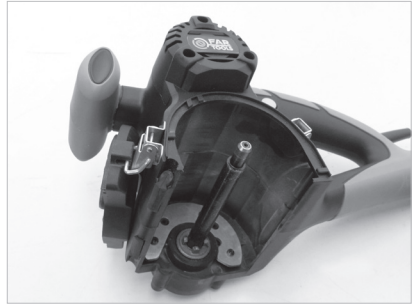
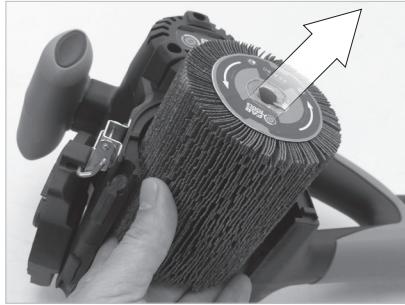





Fonctionnalité de la machine
Functions of the machine

E

01

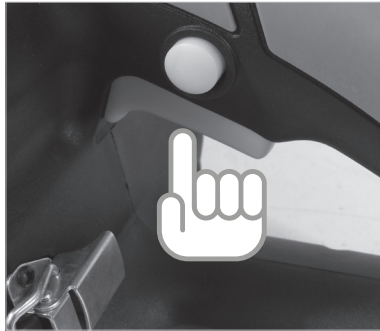
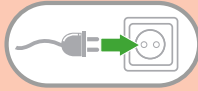

03

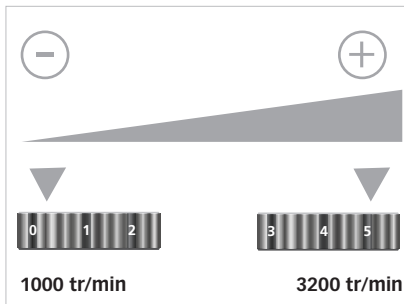
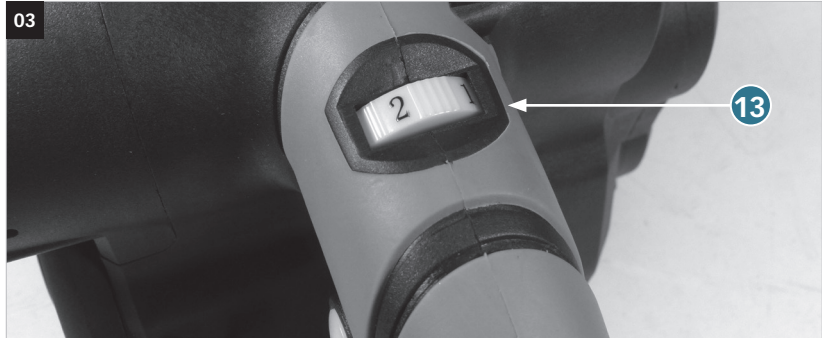

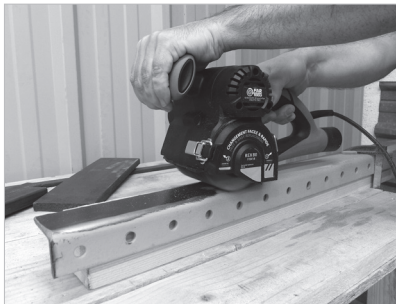
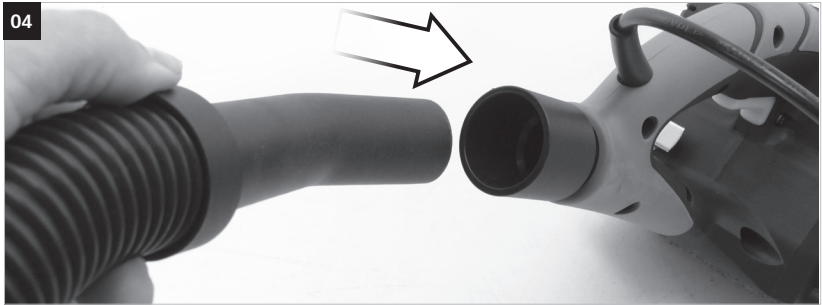



Remplacement des
consommables
Consumables
replacing

G

01

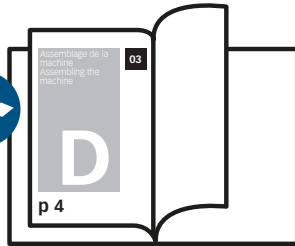

Option - Option - Option - Opcional - Opzione - Opção - Optie - Επιλογή - Opcja - Valinnainen - Tarvikkeet - Tillval - **Допълнително** -
Ekstra udstyr - Opzioni - **Оптация** - seçenek / seçim Volba - Volba - ראיית-עץ - Opció - Možnost - Valik - Opција - Izvēle



110891:
Brosse fil laitonée 0,3 mm
Staalborstel messing 0,3 mm
0,3 mm cepillo de alambre de latón
0,3 millimetros escova de arame de bronze
0,3 millimetri spazzola metallica di ottone
0.3 mm brass wire brush
Messingdrahtbürste



110892:
Brosse Nylon avec fil enrobé d'abrasif
Nylon gecoatete draad borstel met schurende
Cepillo de alambre revestido de nylon con abrasivos
Escova de fio de nylon revestido com abrasivo
Spazzola di filo rivestito in nylon con abrasivo
Nylon coated wire brush with abrasive
Nylon-Drahtbürste mit Schleifmittelbeschichtung

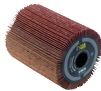

110893:
Brosse à lamelles
Flap Brush
Solapa cepillo
Escova Flap
Spazzola Flap
Flap Brush
Lamellenbürste mit Schleifmittel



110894:
Brosse fibre synthétique
Synthetische vezel penseel
Pincel de fibra sintética
Escova de fibra sintética
Pennello in fibra sintetica
Synthetic fiber brush
Synthetikfaserbürste



110910:
Brosse coton
Katoenen borstel
Cepillo de algodón
Escova de algodão
Spazzola di cotone
Cotton brush
Baumwollbürste



110911:
Brosse carbure de silicium
Siliciumcarbid borstel
Cepillo de carburo de silicio
Escova de carboneto de silicio
Spazzola in carburo di silicio
Silicon carbide brush
Siliziumkarbidbürste



	<p>Tension et fréquence assignée: Nominal frequency and power: Spannung und Frequenz: Tensión y frecuencia fijada: Tensione e frequenza assegnata: Tensão e frequência fixa: Aangewezen spanning en frequentie: Ονομαστική τάση και συχνότητα: Napięcie i częstotliwość przydzielona: Jännite ja määrätty taajuus: Angiven spänning och frekvens: Anført spænding og frekvens: Tensiune și frecvență de lucru:</p>	<p>Заданное напряжение и частота: Tahsis gerilimi ve frekans: Stanovené napětí a frekvence: Stanovené napätie a frekvencia: מחוט ותדר מוקצב. الغلطية والذبذب المبرمجة. Névleges feszültség és frekvencia: Napetost in določena frekvenca: Консумирано напрежение и честота : Määratud pinge ja sagedus Nustatyta įtampa ir dažnis Noteiktais spriegums un frekvence. Napon i nazivna frekvencija:</p>	230 V ~ 50 Hz
---	--	--	---------------

	<p>Puissance assignée: Nominal power: Nennleistung: Potencia fijada: Potenza assegnata: Potência assinada: Onbelast toerental: Ονομαστική ισχύς: Prędkość na biegu jałowym: Teho: Angiven effekt: Anført styrke: Putere de lucru:</p>	<p>Заданная мощность: Tahsis edilen güç: Stanovený příkon: Predpísaný výkon: כוח מוקצב. القدرة المبرمجة. Névleges teljesítmény : Določena jakost: Консумирана мощност: Määratud võimsus. Nustatyta galia Noteiktā jauda Nazivna snaga:</p>	420 W
---	---	---	-------

	<p>Classe d'isolement : 2 Insulation class : 2 Schutzklasse: 2 Aislamiento clase :2 Isolamento classe :2 Isolamento classe :2 Isolatie Klasse : 2 Κατηγορία μόνωσης: 2 Izolacja Klasy :2 Eristysluokka :2 Isolering Klass :2 Isoleringsklasse 2 Clasă izolatie :2</p>	<p>Класс изоляции 2 : Yalitim derecesi :2 Třída izolace :2 Izolačný systém 2 סוג בידוד :2 فئة ال عزل :2 Szigetelési osztály :2 Razred izolacije :2 Инструмент Клас :2 Isolatsiooniklass 2 Izolacijjos rūšis 2 Izolācijas klase 2 Izolacija klasa: 2</p>	X
--	---	--	---

	<p>Vitesse à vide: No-load speed: Leerlaufdrehzahl: Velocidad vacía: Velocità a vuoto: Velocidade no vácuo: Leerlaufdrehzahl: Ταχύτητα αδράνειας: Prędkość bezciążeniowa: Tyhjäkäyntinopeus Tomgångshastighet: Hastighed i ubelastet tilstand: Viteza în gol:</p>	<p>Скорость вращения на холостом ходу: Boşalma hızı: Rychlost naprázdno: Rýchlosť pri chode naprázdno: מהירות ריק. السرعة على الفارغ. Üres sebesség: Prosti tek: Скорост на празни обороти: Kiirus tühikäigul Tuščio prietaiso greitis Tukšgaitas ātrums Brzina praznog hoda:</p>	1000-3200 min ⁻¹
---	---	--	-----------------------------





	<p>Porter des lunettes de sécurité : Wear protective eyewear : Tragen Sie eine Schutzbrille. Llevar puestas gafas protectoras : Portare de gli occhiali di sicurezza : Utilizar óculos de segurança : Draag een veiligheidsbril : Φοράτε προστατευτικά γυαλιά: Zakładać okulary ochronne : Käytä suojalaseja : Använd skyddsglasögon : Der skal benyttes sikkerhedsbriller : Purtati ochelari de protectie :</p>	<p>Наденьте защитные очки : Güvenlik gözlükleri takın : Používejte bezpečnostní brýle : Noste ochranné okuliare : תחישב יפקשמ ביברהל אנ חגל נזפארט וקאי. Viseljen védőszemüveget : Nositi zaščitna očala : Да се използват защитни очила : Kandke kaitseprille Nešioti apsauginius akinius Valkät aizsargbrilles Nositi zaštitne naočale:</p>	X
---	--	---	---

	<p>Porter un masque anti-poussière : Wear a dust mask : Tragen Sie eine Staubschutzmaske. Llevar puesta una careta de protección contra el polvo : Indossare una mascherina anti-polvere : Utilizar uma máscara anti-poeira : Draag een stofmasker : χρήση προστατευτική μάσκα : Zakładać maskę przeciwpyłową Käytä heng : Bär mask mot damm : Der skal benyttes beskyttelsesmaske mod støv: Purtati mască anti-praf :</p>	<p>Наденьте респиратор : Toza karşı maske takın : Používejte masku proti prachu : Noste ochrannú masku proti prachu : קבא דגנ הכסמ שובבל אנ ליס קנאע מראש ללגבאר. Viseljen porvédő maszkot Nositi zaščitno masko proti prahu: Да се използва защитна маска : Kandke tolmumaski. Dėvėti respiratorių Valkät aizsarg masku pret putekļiem Nositi masku za zaštitu od prašine:</p>	X
---	--	---	---

	<p>Porter une protection auditive : Wear hearing protective equipment: Tragen Sie Gehörschutz. Llevar puesta una protección auditiva: Portare una protezione uditiva: Utilizar uma protecção auditiva: Draag gehoorbeschermers: Φοράτε προστασία ακοής: Zakładać słuchawki ochronne Käytä kuulosuojaimia: Bär hörselskydd: Der skal benyttes høreværn: Purtati căști de protectie auz:</p>	<p>наденьте средства звуковой защиты: İşitsel koruma aleti takın: Používejte ochranu sluchu: Noste ochranné slúchadlá: יש ל הרכיב הגנת שמיעה ליס חודצה חרש אלכסחיג Viseljen fülvédőt Nositi zašito ušes: Да се използва слухови защитни средства: Kandke kõrvakaitset Nešioti apsaugā nuo triukšmo Valkät dzirdes aizsarglīdzekli Nositi štītņiņi protiv buke:</p>	X
---	--	--	---

	<p>Porter des gants : Use rubber gloves : Tragen Sie Schutzhandschuhe. Llevar guantes de protección : Indossare i guanti di protezione : Utilizar luvas de protecção : Draag veiligheidshandschoenen : χρήση προστατευτικών γαντιών : Używać rękawic ochronnych : Käytä suojakäsineitä : Använd skyddshandskar : Der skal benyttes handsker : Purtati mănuși :</p>	<p>Наденьте перчатки : Eldiven takın : Noste rukavice : Noste rukavice : תופכב שובבל אנ ליס קנאזאט. Viseljen kesztyű t Nositi rokavice: а се използват предпазни ръкавици : Kandke kindaid Müvēti pirštines Valkät cimdus Nositi zaštitne rukavice:</p>	X
---	--	---	---



	<p>Lire les instructions avant usage : Read the instructions before use : Lesen Sie vor Einsatz des Geräts die Bedienungsanweisung. Léase las instrucciones antes de usar : Leggere le istruzioni prima dell'uso : Ler as instruções antes da utilização : Lees voor het gebruik de instructies : Διαβάστε τις οδηγίες πριν από τη χρήση: Zapoznać się instrukcją przed użyciem : Lue ohjeet ennen käyttöä : Läs anvisningarna före användning : læs instruktionerne før brug Înainte de utilizare, cititi instructiunile :</p>	<p>Внимательно прочитайте следующие инструкции : Kullanmadan talimatları okuyunuz : Pozorně si přečtěte následující pokyny : Pred použitím si prečítajte pokyny : דרום חילופי اقرأ التعليمات قبل الاستخدام. használat előtt olvassuk el az utasítást : Pred uporabo preberite ustrezna navodila Прочетете указанията за употреба : Enne kasutamist lugege instruksiooni Prieš naudojimą perskaityti instrukciją izlasīt instrukcijas pirms lietošanas Pročitati upute prije uporabe:</p>	X
--	---	---	---

	<p>Conformité européenne CE Conforms to EC standards : CE-Konformität : Cumples con las directivas CE : Conforme alle norme CE : Conforme às normas CE : Voldoet aan de EG-normen : Ευρωπαϊκή συμμόρφωση CE Zgodność z normami CE : EU-standardien mukainen : EU-standardien mukainen : Overholder EU standarderne : Conform cu normele europene:</p>	<p>соответствие европейским стандартам: Avrupa uygunluk : evropská shoda : európska dohoda : התאמה לתקנים האירופיים مطابقت للجواصفات الأوروبية. evropska ustreznost : európai megfeleléség : Съответствие с европейските норми : Euroopa Liidu vastavusmärk Europinių normų atitikima Atbilstība Eiropas standartiem Euroopska sukladnost</p>	X
--	---	---	---

	<p>Danger : Danger : Gefahr : Peligro : Pericolo : Perigo : Gevaar : Κίνδυνος: Niebezpieczeństwo : Vaara : Fara : Fare : Pericol :</p>	<p>Опасно : Tehlike : Nebezpečí : Nebezpečenstvo : סכנה. خطر. Veszély : Nevarnost: Опасност : Oht Pavojus Bīstamība Opasnost:</p>	X
--	--	---	---

	<p>Poids : Weight : Gewicht : Peso : Peso : Peso : Gewicht : Βάρος : Masa : Paino : Vikt : Vægt : Greutate :</p>	<p>Вес : Ağirlik : Hmotnost : Hmotnosť : משקל الوزن. Súly : Teža : Тегло : Raskus Svoris Svars Težina</p>	2,7 kg
--	--	--	--------





 L_{pA}	Niveau de pression acoustique :	Уровень акустического давления. :	87 dB (A)
	Acoustic pressure level :	Akustik basınç seviyesi :	
	Schalldruckpegel :	Hladina akustického tlaku :	
	Nivel de presi3n ac3stica :	Hladina akustického tlaku :	
	Livello di pressione acustica :	רמת לחץ אקוסטי.	
	Nivel de presi3o ac3stica :	مستوى الضغط السمعي.	
	Niveau akoestische druk :	A hangnyom3s szintje :	
	Στάθμη ηχητικής πίεσης:	Nivo akustičnega pritiska:	
	Poziom mocy akustycznej :	Равнище на акустично налягане :	
	Äänenpainetaso :	Helirõhu nivoo	
	Ljudtrycksnivå :	Akustinio spaudimo lygis	
	Ljudtryk :	Akustisk3 spiediena l3menis	
Nivel presiune acustic3 :	Razina zvučnog tlaka:		

 L_{wA}	Niveau de puissance acoustique :	уровень мощности звука :	98 dB (A)
	Acoustic power level :	Akustik basınç seviyesi :	
	Schalleistungspegel :	Hladina zvukového výkonu:	
	Nivel de potencia ac3stica :	Hladina zvukového výkonu:	
	Livello di potenza acustica:	רמת כוח אקוסטי.	
	Nivel de pot3ncia ac3stica:	مستوى الضجيج.	
	Niveau akoestisch vermogen :	a hangnyom3s szintje :	
	Επίπεδο ισχύος ήχου:	Nivo akustične jakosti :	
	Poziom mocy akustycznej :	Равнище на вибрации :	
	Äänitehotaso :	Helivõimsuse nivoo	
	Ljudstyrkenivå :	Triukšmo lygis	
	Ljudstyrke :	Akustisk3s jaudas l3menis	
Nivel putere acustic3 :	Razina zvučne snage:		

NIVEAU SONORE D'ÉMISSION :

A VIDE

Pression acoustique L_{pA} poste opérateur
Incertitude

87 dB
3

Puissance acoustique L_{wA}
Incertitude

98 dB
3

Valeurs déterminées suivant le code d'essai de l'annexe B de la norme EN 61029-1 avec emploi des normes de base ISO 11201 et ISO 3744.

Les niveaux de pression acoustique obtenus in situ dépendent:

- Des niveaux réels de la machine considérées, en prenant en compte les incertitudes déclarées;
- Du local et de l'installation de la machine. Préférez une pièce dont l'acoustique est plus feutrée. Evitez les pièces vide à grande résonance. Placez vous auprès d'une fenêtre le cas échéant.
- Des outils montés, des pièces travaillées, des réglages choisis,...

 L_v	Niveau de vibration :	Уровень вибрации :	14,6 m / s ²
	Hand/arm vibration level :	Titr3sim seviyesi :	
	Vibrationspegel Hand/Arm :	Úroveň vibrací :	
	Nivel de vibraci3n mano/brazo :	Hladina vibracíí :	
	Livello di vibrazione mano/braccio :	רמת תנודות	
	Nivel de vibraç3o mão/braço :	مستوى الارتجاج.	
	Trillingsniveau hand/arm :	Vibráci3szint :	
	Επίπεδο κραδασμών:	Nivo vibracij :	
	Poziom vibracji r3zka/ramiż :	Равнище :	
	T3irin3taso:	Vibr3cijas l3menis.	
	Vibrationsnivå hand/arm :	Vibracij3s lygis	
	Vibrationsniveau :	Vibratsiooni nivo	
Nivel vibrati3i :	Razina vibracije:		

VIBRATIONS:

Total des valeurs de vibration (somme vectorielle des trois directions) déterminée selon EN 60745 :

a 14,6 m/s²
Incertitude K 1,5 m/s²

L'amplitude d'oscillation peut être utilisée comme valeur de comparaison d'outils électroportatifs.
Attention : si l'outil électroportatif est utilisé pour d'autres applications, avec d'autres outils de travail, l'amplitude d'oscillation peut être différente.



	<p>Soumis à recyclage Subjected to recycling Sujeto a reciclaje Sottoposti a riciclaggio Führen Sie das Gerät dem Recycling Não deite no lixo : Niet wegwerpen : Μην την πετάτε : Nie wyrzucac : Älä heittä pois luontoon : Batteriet får inte kastas : Bortkast det ikke: Nu le auncati :</p>	<p>Не выбрасывайте в мусорный ящик Atmayınız : Nevyhadzujte je do bežného odpadu : Neodhadzovat : אין לרוק סוללות فلا ترمدها لهذا في القمامة. ne mečíte1 Ne odvržite ga/jih vstran : Не го изхвърляйте : Ärge visake seda minema : Nemétykíte : Nemest : Podvrgnuto recikliranju</p>	X
---	--	--	---

Recyclage des déchets :

Les outils, accessoires et leur emballages doivent suivre une voie de recyclage adaptée. Conformément aux directives Européenne 2012/19/UE et 2006/66/CE, les composants d'un produit doivent être séparés, collectés, recyclés ou éliminés en conformité avec les réglementations environnementales en vigueur. Les appareils, batteries, piles, huiles, emballages devront être déposés dans les systèmes d'élimination des déchets spéciaux tels que déchetteries. Renseignez-vous auprès de votre commune pour connaître l'organisme le plus proche à même de retraiter ou de collecter ces déchets.

DE

Recyclingfähige Materialien :

Hinweis: Umweltschutz und Entsorgung

Der Verbraucher ist gesetzlich dazu verpflichtet, elektronische Geräte, Lampen und Batterien am Ende ihrer Lebensdauer ordnungsgemäß zu entsorgen.
An den öffentlichen Sammelstellen oder bei Händlern können diese unentgeltlich zurückgegeben werden. Die Löschung der Personenbezogenen Daten liegt in der Eigenverantwortung des Verbrauchers. Leuchtmittel und Batterien, welche gefahrlos entnommen werden können und nicht fest verbaut sind, müssen zur separaten Entsorgung vorab entnommen werden. Das Landesrecht regelt die Details der rechtskonformen Entsorgung. Die Kennzeichnung mit der durchgestrichenen Mülltonne markiert Elektrogeräte und Batterien, die nach ihrer Lebensdauer auf keinen Fall im Hausmüll entsorgt werden dürfen. Unter der Mülltonne angebrachte Symbole, kennzeichnen evtl. enthaltene Inhaltsstoffe (Blei = Pb, Quecksilber = Hg, Cadmium = Cd). Diese Trennung ist nötig, da Batterien und Elektrogeräte sowohl wertvolle Ressourcen sind als auch für den Menschen und seine Umwelt schädliche Stoffe enthalten. Durch Verwertung, Sammlung und Wiederverwendung der hierfür geeigneten Batterien und Elektrogeräte tragen Sie zum Erhalt und Schutz der Umwelt und der menschlichen Gesundheit bei.

	<p>Recyclable, soumis au tri sélectif Recyclable, subject to recycling Trennen Sie recyclingfähige Materialien ordnungsgemäß. Reciclables, sujetos a reciclaje Riciclabili, soggetti a riciclaggio Recicláveis, sujeito à reciclagem Recycleerbare, onderworpen aan recycling Ανακυκλώσιμες συσκευασίες που υπόκεινται σε κύκλωση Opakowanie nadaje się do recyklingu podlegają recyklingu Kierrätettävä pakkausmateriaali Återvinningsbara förpackningar omfattas återvinning Рециклираци се опаковки подлежат на рециклиране Genanvendelig underlagt genbrug</p>	<p>Reciclabile sub rezerva reciclare Повторно опаковка подлежит вторичной переработке Gerü dönüştürme Gerü dönüştürülebilir ambalaj konusu Recyklovateľné podléhající recyklaci Recyklovateľné podliehajúce recyklácii החמל הישראלית ريودنلا خا يال يعضت ريودنلا خا يال قبااولا لسيول نخلال و قوب يخل Újrahasznosítható csomagolás alá újrahasznosítás Reciklirati predmet recikliranje Pakendite suhtes ringlussevõtu Pärstrådājams iepakojums otrreizējai pārstrādei Perdirbamų taikomos perdirbimo Može se reciklirati, podložno selektivnom sortiranju</p>	X
---	---	---	---

	<p>Diamètre de brosse et largeur : Diameter of wheel and width : Bürstendurchmesser und Breite : Cepillar diámetro y anchura: Escovar diâmetro e largura: Spennellare diametro e larghezza: Borstel diameter en breedte: Διάμετρο δίσκου : Srednica tarczy i otwór : Laikan sisä- ja ulkomitta : Skivans diameter och innerdiameter : Skivens ydre og indre diameter : Diametru disc și alezaj :</p>	<p>Диаметр диска и пропила : Disk ve delik çapı : Průměr kotouče a vrtání : Priemer kotúča a vnútorný priemer : קוטר הדיסקה וקידוד قطر الأسطوانة والتجويف A tárcsa és a furat mérete : Premer diska in izvrtine : Диаметър на резаца : Ketta ja puurimise diameeter : Skersmuo : Diska un caurplūdes atvērums diametrs : Promjer četke i širina:</p>	ø 80 x 100 mm
---	--	---	---------------





REX 80

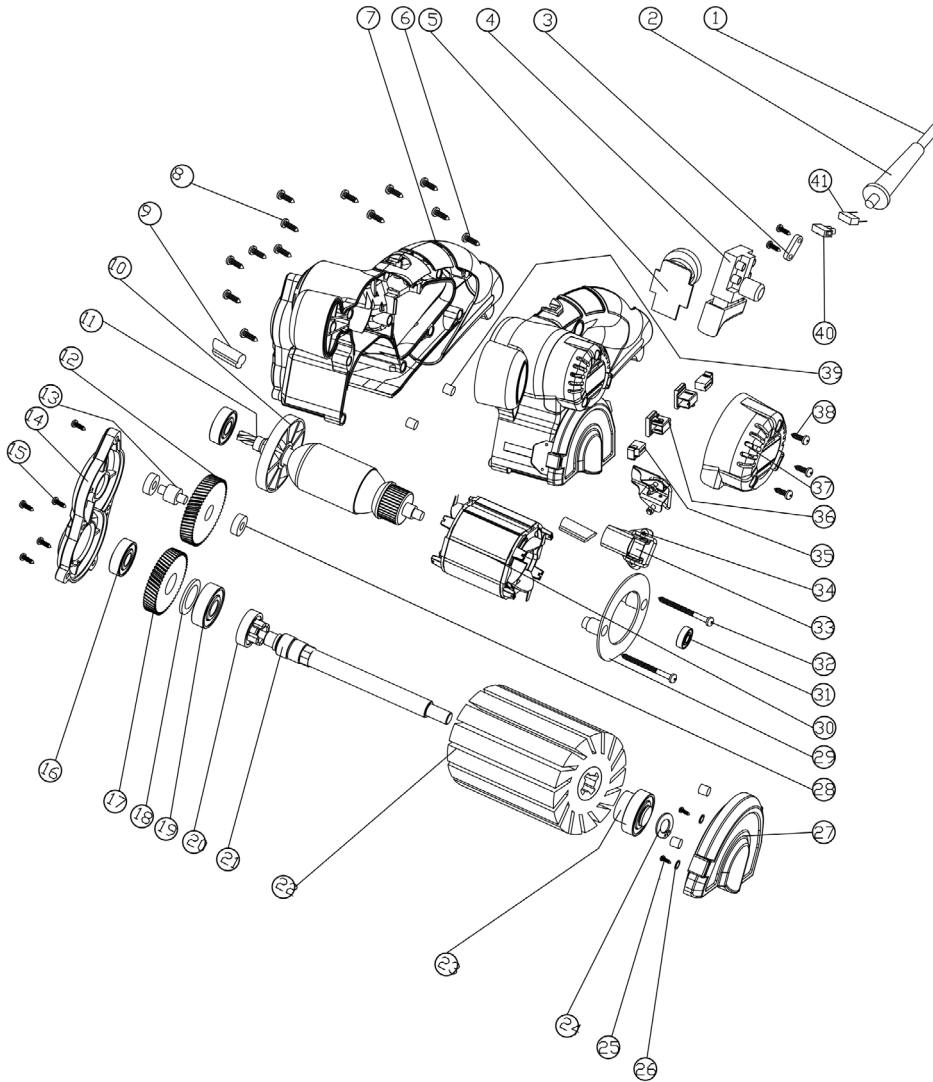

DECLARATION DE CONFORMITE
VERKLARING VAN OVEREENSTEMMING
DECLARACION DE CONFORMIDAD
DICHIARAZIONE DI CONFORMITA
KONFORMITÄSERKLÄRUNG
DECLARATION CONFORMITY
DECLARAÇÃO DE CONFORMIDADE
DEKLARACJA ZGODNOSCI Z NORMAMI
OM ÖVERENSSTÄMMELE
VAATIMUSTENMUKAISUUSVAKUUTUS
OVERENSSTEMMELESEKLERING
ΔΗΛΩΣΗ ΣΥΜΜΟΡΦΩΣΗΣ

DECLARAȚIE DE CONFORMITATE
VYHLÁSENIE ZHODY
Декларация соответствия
הצהרת תואמת
Uygunluk beyanı
التصريح بالخطابفة
PROHLÁŠENÍ SHODY
EGYEZŐSÉGI NYILATKOZAT
Декларация за съответствие с нормите
IZJAVA O SKLADNOSTI
DEKLARACIJA
ATTIKTIES DEKLARACIJA
KINNITUS
IZJAVA O SUKLADNOSTI

Le soussigné,
Ondergetekende,
Der Unterzeichner,
O abaixo assinado,
Undertecknad,
Долуподписаният
Undertegnede
Subsemnatul,
Я, нижеподписавшийся,
Imzalayan,
Niže potpisany,
Toliau pasirašęs

Déclare par la présente que,
Verklaart hiermede dat,
Erklärt hiermit daß,
Declara pela presente que,
Förklarar härmed att
Заявлява с настоящото
erklærer hermed, at
Declar prin prezenta că,
настоящим подтверждаю, что
Mevcut belgeyle beyan ediliyor ki,
tímto prohlašuje, že,
Pareiškia, kad,

Personne autorisée à constituer
le dossier technique :
Christophe HUREL



FAR GROUP EUROPE
192, Avenue Yves Farge
37700 St. Pierre-des-Corps
FRANCE

El suscrito,
Il sottoscritto,
The undersigned,
Ninei potpisany
Allékirjoittanut,
Ο κάτωθι υπογεγραμμένος,
Nižise potpisany
החתום מתה
الذوق أعزناه
Alulírott,
Podpisani,
Apakšā pārkstījies
allakirjutanu
Dolje potpisani,

Declaro por la presente, que,
Dichiare che,
Declares that,
Oświadczam niniejszym, że
vakuuttaa täten että
Δια του παρόντος δηλώνει ότι,
týmto vyhlasuje, že
מהיר בה כי
يصرح استنادا على ذلك
kijelentem, hogy a készülék Izjavlja da,
Pareiškia, kad,
Ar šo apliecinā, ka,
Kinnitab, et
Izjavljuje u ovom dokumentu da je

Rénovateur compact / Compact renovator / Kompakter Renovierungsschleifer / Renovador compacto / Rinnovatore compatto / Renovador compacto /
Compacte renovatie / Συμβαλός ανακαινιστής / Kompaktowy remont / Kompakti hviomakone / Kompakti renoverare / Компактен ремонт /
Kompakt renovering / Renovator compact / Компактный ремонт / Kompakt renovator / Kompakti restaurátor / Felújító kompakt / Obnovitelj
Kompakten / Renovererija kompaktna / Renovators kompakts / Renovatorius kompaktiškas / Renovator kompaktni

code

FARTOOLS / 115018 / REX 80 / JD2676

Est conforme et satisfait aux directives et normes CE,
In overeenstemming is met en Voldoet aan EG richtlijnen,
Den nächstehenden EU Richtlinien übereinstimmt.
Respeita e está em conformidade com as normas CE,
Överensstämmer med och uppfyller EG-standarder,
Съответства и отговаря европейските норми
Er i overensstemmelse med og overholder EU standarderne
Este conform și satisface normele CE
полностью соответствует и удовлетворяет
требованиям стандартов ЕС
CE sartzlara uygundur,
odpovídá normám ES.
Atitinka ir atitinka EB direktyvas ir standartus,

Cumple con la directivas de la CE,
E conforme alle direttive CEE,
Complies with the EEC directives and standards,
Odpowiada normom UE,
Täyttää EU-vaatimukset,
Συμμορφώνεται τις οδηγίες και τα πρότυπα CE,
zodpovedá normám ES.
מתאים ועונה לתקני
באן הרגאז יטאבף ו ילבי מראי מרצועה الدول الأوروبية
kielegíti a CE szabványok előírásait.
Je v skladu z in izpolnjuje norme Evropske skupnosti.
Atbilst un atbilst EK direktīvas un standartus.
Vastab ja vastab EU direktīvidele ja standardeite,
Sukladan i ispunjava direktive i standarde CE,

2014/30/EU MD :2006/42/EC 2015/863/EU
2011/65/EU

ENIEC55014-1:2021
ENIEC55014-2:2021
ENIEC61000-3-2:2019/A1:2021
EN61000-3-3:2013/A2:2021
EN62841-1:2015/A11:2022
EN62841-2-4:2014

Christophe HUREL,
Président Directeur Général
16/09/2023
Fait à St. Pierre-des-Corps



115018-Sticker-04-A-Logo.indd 1 28/02/2020 14:42

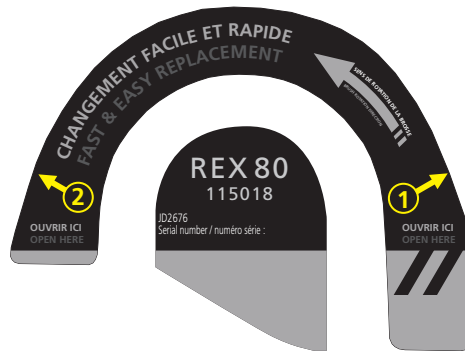
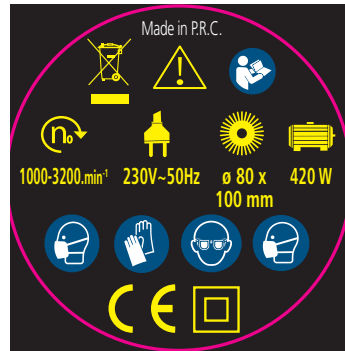

GARANTIE - WARRANTY

3 ANS

GARANTIE

RO. GARANTIE

Acest aparat este garantat din punct de vedere contractual împotriva tuturor vicilor de construcție și de material, începând de la data vânzării lui către utilizator și la simpla prezentare a bonului de casă. Garanția constă în înlocuirea componentelor defecte. Această garanție nu se aplică în cazul exploatarei în alt mod decât cel recomandat de normele aparatului și nici în caz de stricăciuni provocate de intervenții neautorizate sau prin neglijența cumpărătorului. Garanția nu se aplică asupra pagbelor cauzate de o defectare a aparatului.

RU. ГАРАНТИЯ

Данное изделие обладает имеющей силу контракта гарантией, покрывающей все возможные дефекты изготовления и материала. Гарантия вступает в силу с даты продажи изделия пользователю, для этого достаточно сохранить и предъявить полученный в кассе чек. Гарантия обязывает изготовителя заменить дефектные части изделия. В случае не соответствующего нормам использования изделия, несанкционированного демонтажа или ремонта или небрежного обращения действие гарантии прекращается. Гарантия не покрывает ущерба, возникшего в результате сбоев в работе изделия.

TU. GARANTI

Bu arac, satıs tarihinden itibaren, kullanıcının sadece vezne alıncısına sunmasıyla tüm üretim ve malzeme hatasına karşı garantilidir. Garanti eksik olan kısımları degistirmek icindir. Bu garanti aracin sartlarina uygun olmayan isleme durumunda, izin verilmeyen kullanimlardan kaynaklanan hasarlarda veya alıcının istegi durumunda uygulanmaz. Garanti malzemenin bir eksikliginden meydana gelen bir zararda uygulanmaz.

CS. ZÁRUKA

Pro tento nástroj platí smluvní záruka na všechny výrobní a materiálové vady od data prodeje uživateli a na základě předložení pokladního bloku. Záruka spočívá ve výměně vadných částí. Tato záruka neplatí v případě použití přístroje, které neodpovídá normám, ani v případě škod způsobených nepovolenými zásahy nebo nedbalostí ze strany kupujícího. Záruka se nevztahuje na škody způsobené zavadou nástroje.

SK. ZÁRUKA

Pre tento nástroj platí zmluvná záruka na všetky výrobné a materiálové chyby od dátumu predaja užívateľovi a na základe predloženia poklad-

ničného bloku. Záruka spočíva vo výmene chybných častí. Táto záruka neplatí v prípade použitia prístroja, ktoré neodpovedá normám, ani v prípade škod spôsobených nepovolenými zásahmi alebo nedbalosťou zo strany kupujúceho. Záruka sa nevztahuje na škody spôsobené poruchou nástroja

HE. אחריות

הצגת חשבונית קופה. האחריות-משמעה או בחומרה, החל מיום המכירה למשתמש עם זה חלה אחריות לפי חחה מפני כל ליקוי בציוד. נזק שנגרם על ידי התערבות תללא הי עלכלי במכשיר שאינו מתאים לתקנים ובמקרה של הלקויים אחריות זו אינה חלה במקרה של שימוש על נזק שנגרם על ידי תקלה בכלל. החלף תחלקם ידי רשלנות מאת הקונה. האחריות אינה חלה מוכתה או זה

AR. الضمان

وبناء على مجرد تقديم بطاقة الشراء يت على ق اغتبارا من تاريخ البيع الى الحس عمل من أي غيب فتي التصدي عوفيا الجواد. لتللافاص ان مدة الع دة مضمونة تعاقديا البطابق لم عايير الاجهاز. ول في حالة تعرضه قابل للتطبيع في حالة الايتخدام غير ستبدال الاجزاء العاطلة لا يكون هذا الضمان على الصورد الزناج عن غل الخدمان في الامل من قبل الحسيري ل يطبق الضمان عن عمليات تدخل غير مدمصة او في حالة ناطة

HU. GARANCIA

Erre a szerszámra szerződéses garanciát vállalunk bármilyen gyártási és anyaghiba felmerése esetére, a fogvasztó részére történt eladás napjától számítva, a penztári blokk egyszerű felmutatása elleneben. A garancia a hibás alkatrészek cserejére terjed ki. Ez a garancia nem érvényes, ha a készüléket nem rendeltetészerűen használták, sem illetéktelen beavatkozások, vagy a vásárló hanyagsága okozta károk esetén. A garancia nem fedezi azokat a károkat, melyeket a szerszám hibás működése okozott.

SI. GARANCIJA

To orodje je z garancijsko pogodbo zaščiteno proti vsem napakam v izdelavi in v sestavnem materialu od datuma prodaje naprej in ta velja ob predložitvi blagajniškega računa. Garancija velja za zamenjavo delov z napako. Ta garancija ne velja za uporabo orodja, ki ni v skladu z normami, predpisanimi za omenjeno orodje in za primere okvar, ki nastanejo zaradi nedovoljenih posegov na orodju ali zaradi malomarnega rokovanja kupca. Garancija ne velja za škodo, ki jo lahko povzroči okvara orodja.

PL. GARRANTII

See tööriist kuulub lepingu järgi garantiiremonti arvestades alates müümise päevast ja kassatseki alusel kasutajale kõigi konstruktsiooni- ja materjalvigade puhul. Garantii seisneb defektsete osade väljavahetamisest. See garantii ei kehti aparadi normide ebatavalise eiramise puhul ega ostja poolt keelatud viisil kasutamisest või hooletussejätmisest tule-

nevate kahjude korral. Garantii ei kehti seadme defektidest põhjustatud kahjude puhul

LV. GARANTIJA

Sis prietaisais yra užtikrinamas kaip itin geros kokybės, nuo jo pardavimo datos iki jo panaudojimo, ir jam yra suteikiamas garantinis talonas. Garantijos metu galima pakeisti atsiadusius trumplaalaikius gedimus. Si garantija netaikoma esant netinkamam naudojimui ar nesilaikant reikiam šio aparato vartojimo instrukcijų, tai pat pačiam pirkejuji sugadinus. Garantija taip pat netaikoma, prietaisa naudojant ne pagal paskirtį ir jį apgadinus

LT. GARANTIJA

Šim darbarikam ir liguma noteikta garantija visiem defektium, kas saistais ar konstrukciju un materialu, sākot ar pārdošanas datumu, kad mašīnu pārdod lietotājam un vienkārsi uzrādot kases čeku. Garantija iekļauj bojāto daļu nomaiņu. Si garantija nav derīga, ja aparats nav lietots saskaņā ar drošības noteikumiem, ne gādījumos ja bojājumi radušies nesankcionētas iekļaušanas gadījumā vai arī pierceja nolaidības dēļ. Garantija nav derīga ja bojājumi radušies darbarika defekta dēļ

HR. JAMSTVO

Ovaj alat ima ugovorno jamstvo u slučaju bilo kakvih nedostataka u konstrukciji i materijalu, od datuma prodaje korisniku uz jedinstavno predocenje racuna. Jamstvo se sastoji u zamjeni neispravnih dijelova. Ovo se jamstvo ne primjenjuje u slučaju uporabe i eksploatacije koja nije sukladna standardima uređaja, niti u slučaju štete uzrokovane neovlastenim intervencijama ili nemarkom kupca. Jamstvo se ne primjenjuje na štetu uzrokovanu nekim nedostatkom alata.

SERVICE APRÈS VENTE - AFTER SALE SERVICE

FARGROUP EUROPE - 192, Avenue Yves Farge - 37700 St. Pierre-des-Corps - FRANCE

fargroup@fargroup.net



FAR GROUP EUROPE

Une société du groupe **SIGMA**

fargroup@fargroup.net
192, Avenue Yves Farge
37700 St. Pierre-des-Corps
FRANCE

fartools.com
fargroup@fargroup.net

