

ANDES

PANADERO



MAßE

MAßE H x B x T	865x467x408 mm
GEWICHT BRUTTO/NETTO	115/100 kg
MAßE FEUERRAUMTÜR	290x360 mm
DURCHMESSER DES ABGASSTÜTZEN	Ø 150-153 mm Oben

EIGENSCHAFTEN

ROST AUS GUSSEISEN	
BLECHGEHÄUSE	5 mm
NENNLEISTUNG	7,5 KW
WIRKUNGSGRAD	80,7 %
CO - EMISSIONEN	0,12 %
HITZESCHUTZANSTRICH	800°C
GLASKERAMIKSCHEIBE HITZEBESTÄNDIG BIS	750°C

EAN 8426964185003
REF. PANADERO 18500

PRODUKT PLUS

ECODESIGN



**EXTERNE
LUFTZUFUHR**



RAUMHEIZVERMÖGEN



VERMICULIT AUSKLEIDUNG



SCHEIBENSPÜLUNG



DREIFACHVERBRENNUNG



SCHEITLÄNGE 40 CM



BEDRUCKTE GLASKERAMIK



HOLZFACH

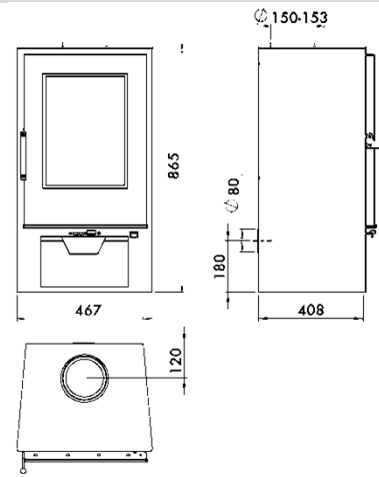

ANDES DE

