

SUERTE

PANADERO



MAßE

MAßE H x B x T **998x496x443 mm**

GEWICHT BRUTTO/NETTO **148/133 kg**

MAßE FEUERRAUMTÜR **711x444 mm**

DURCHMESSER DES
ABGASSTUTZEN **Ø 150-153 mm
Oben**

EIGENSCHAFTEN

ROST AUS GUSSEISEN

DREISEITIGE FEUERANSICHT

BLECHGEHÄUSE **5 mm**

NENNLEISTUNG **8 KW**

WIRKUNGSGRAD **80,7 %**

CO - EMISSIONEN **0,12 %**

HITZESCHUTZANSTRICH **800°C**

GLASKERAMIKSCHEIBE HITZEBESTÄNDIG BIS **750°C**

EAN 8426964481501
REF. PANADERO 48150

PRODUKT PLUS

ECODESIGN



**EXTERNE
LUFTZUFUHR**

**240
m³**

RAUMHEIZVERMÖGEN



VERMICULIT
AUSKLEIDUNG



SCHEIBENSPÜLUNG



DREIFACHVERBRENNUNG



SCHEITLÄNGE 50 CM



HOLZFACH



2-PUNKT VERSCHLUSS

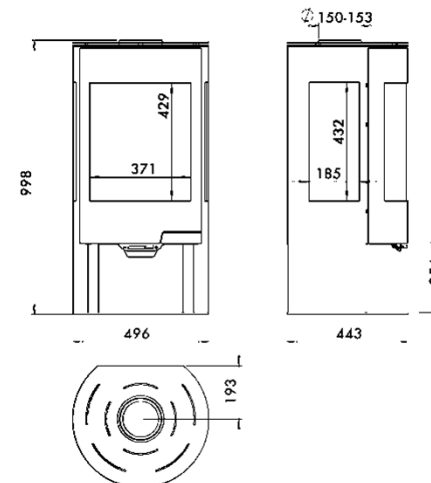

SUERTE DE

